



- CHEMICAL RESISTANT
- SELF-CLEANING
- FLEXIBLE
- HYGIENIC

Corroflon

CONVOLUTED PTFE LINED HOSE

Contents

Front Cover	Page 1
Contents	Page 2
PTFE - The Optimum Choice For Hose Linings	Page 3
Aflex Hose and Corroflon	Page 4
Corroflon Temperatures, Pressures & Flow Rates	Page 5
Corroflon Sizes, Grades, Bend Radius and Dimensions	Page 6
Corroflon Sizes, Grades, Pressure Ratings and Weights	Page 7
Corroflon Special Usage Conditions	Page 8
Quality Assurance Certification & Approvals and Hose Testing	Page 9
How to Order Corroflon	Page 10
Corroflon Part Number System	Page 11
<u>HOSE</u>	
Corroflon Hose Liners	Page 12
Corroflon Hose Braids (and Electrical Continuity)	Page 13
Corroflon Rubber Covers	Page 14
Corroflon External Protection Systems	Page 15
<u>FLANGE FITTINGS</u>	
Flange Fittings, Non-Lined	Page 16
Flange Fittings, PTFE Lined	Page 17
<u>CAM AND GROOVE FITTINGS (CAMLOCKS)</u>	
Female Cam & Groove Fittings, PTFE Lined and Not Lined	Page 18
Male Cam & Groove Fittings, PTFE Lined and Not Lined and Cam Male-to-Flange Adaptors, PTFE Lined	Page 19
<u>SANITARY (TRICLOVER) FITTINGS</u>	
Mini Sanitary & Sanitary Triclover Fittings, PTFE Lined	Page 20
Mini Sanitary & Sanitary Triclover Fittings, Not Lined	Page 21
90° Elbow Sanitary Triclover Fittings, Not Lined	Page 22
<u>HYGIENIC FITTINGS (EUROPEAN)</u>	
DIN11851 Male & Female Fittings, PTFE Lined and DIN11851 Female Fittings, Non-Lined	Page 23
SMS and RJT Female Fittings, PTFE Lined	Page 24
<u>BSP, NPT & JIC THREADED FITTINGS (Not Lined)</u>	
NPT & BSPT Fixed Male and NPT Fixed Female Fittings	Page 25
BSP 60° Cone Seat Female Fittings and Lug-Type Female Fittings	Page 26
37° JIC Female Fittings & NPT Male or Female Unions	Page 27
<u>PTFE Dip Pipes</u>	
PTFE Dip Pipes, Straight or 90° Elbow	Page 28
<u>90° ELBOW FITTINGS</u>	
90° Elbow Fittings, PTFE Lined and Non-Lined	Page 29
<u>HEAT JACKETED HOSE ASSEMBLIES</u>	
Steam Heated Hose Assemblies (CH Grade)	Page 30
Electrically Trace Heated Hose Assemblies (ETH Grade)	Page 31
<u>CORROFLON STANDARD AND PURETAG LABELLING & COLOUR CODING</u>	
Page 32	
<u>CORRECT HOSE CONFIGURATION & LENGTH CALCULATIONS</u>	
Bend Radius	Page 33
Abrasion & Torque	Page 34
Length Calculation	Page 35
<u>CONDITIONS OF SALE</u>	
Pages 36 & 37	

PTFE - The Optimum Choice For Hose Linings

Section from a PTFE Molecule,
16 Angstrom Units long.

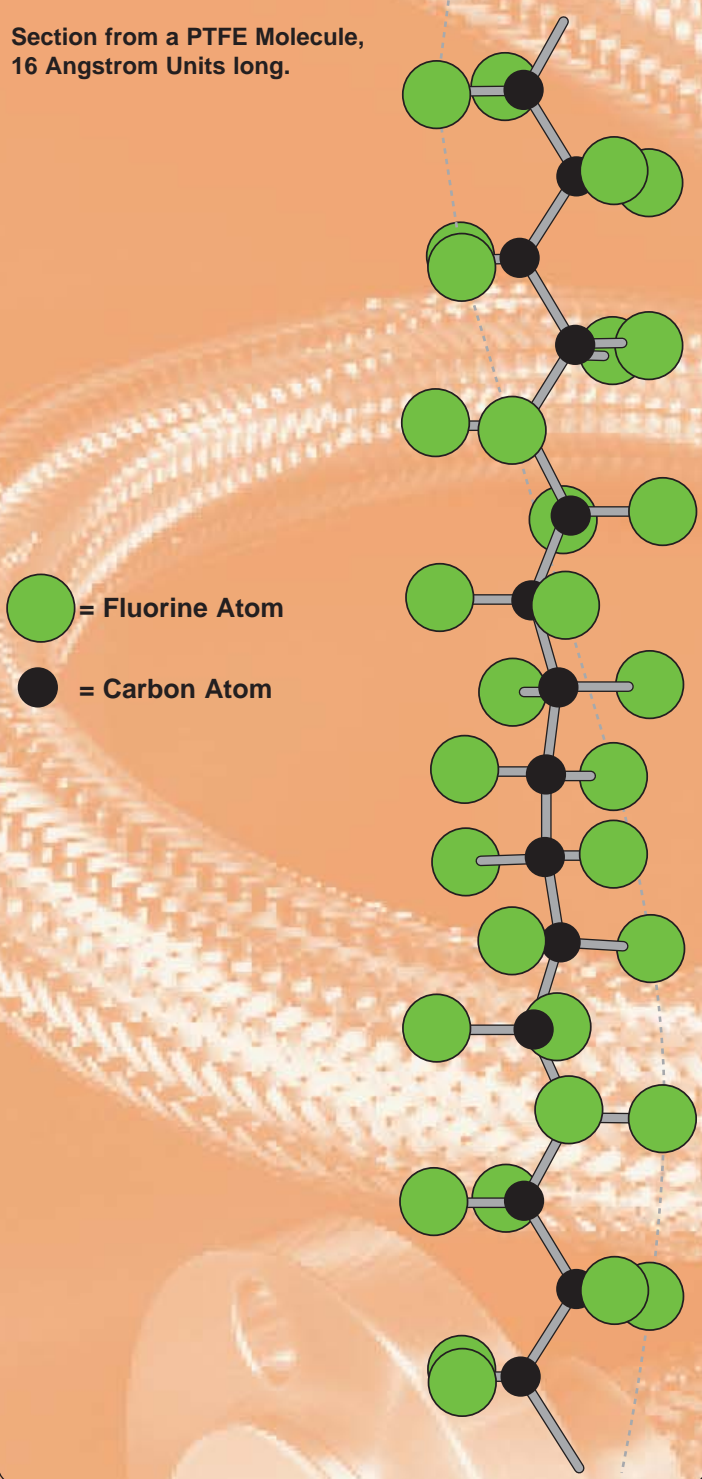

聚四氟乙烯，英文简称PTFE，其化学结构式为： CF_3

$(CF_2CF_2)_nCF_3$ ，PTFE分子长链由碳原子构成，每个碳原子又与两个氟原子相链接。

氟原子几乎覆盖了整个螺旋状高分子链的碳原子表面，非常好的保护了内部碳原子。

此分子结构创造了PTFE其无与伦比的各项物理化学特性。

优异的化学抗性

PTFE是已知材料中化学抗性最好的，只有某些特殊用途或介质可以影响它，比如高温高压状态下的氟气/液态氟，熔融状态的某些碱性金属。

鉴于其优异特性，内衬PTFE的软管较普通软管的使用范围、化学抗性更广，是输送腐蚀性介质或某些复杂介质的理想软管。

表面不粘性

日常生活中的不粘锅厨具就已经很好的说明了PTFE表面的不沾特性。

同样，内衬PTFE软管也就较其他种类的软管在易于清洗方面更快速、可靠。

耐温范围广

不粘锅等厨具也从另一个方面展示了PTFE材料的另一个特性：耐高温。软管的PTFE材料本身可耐零下150摄氏度的低温与260摄氏度的高温，不过软管的耐温范围需要根据软管的设计与应用条件来估算。

PTFE材料的耐温范围超出了任何橡胶和塑料软管的耐温范围。

软管设计

用PTFE作为软管内衬，需要考虑的主要问题是怎么样用更好的软管设计来发挥PTFE的物理化学特性优势，这也是Aflex在过去三十多年一直成功的原因所在。

Aflex品牌之Corroflon系列软管

全球PTFE软管领先制造商

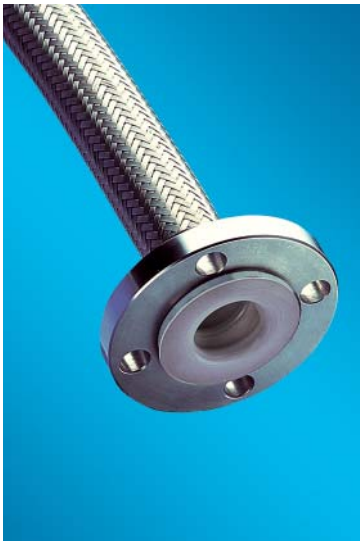

Aflex, 30多年前率先倡导使用PTFE内衬软管作为液体输送用途, 一直引领PTFE软管制造技术。Aflex既提供Bioflex/Corroline/Pharmaline平滑内壁特氟龙软管, 也生产Corroflon 螺旋内壁特氟龙软管, 它们被广泛应用于全球化工、制药、食品等行业。

在过去的几十年当中, Aflex根据不同客户的特定要求, 生产设计了成千上万的定制软管, 公司也一直致力于最新产品的研发和产品线的拓展, 来满足客户的不断苛刻要求。

Corroflon

螺旋、钢丝强化PTFE内衬软管

Corroflon软管始于1978年, 这之后我们对设计进行不断地改进与提高。现在, 此螺旋软管被应用于全球各行业, 这包括一些大的化工、制药和食品公司。

Corroflon的成功主要取决于其独特的软管设计与极高的质量, 从而使得软管寿命更长、使用更安全、更可靠。

Corroflon不同于市面上常见的其他螺旋PTFE软管, 其设计也存在独特性, 这保证了软管性能的优异与使用的可靠。

首先, Corroflon比市场上传统螺旋PTFE软管更易于清洁, 流通性能也更好。这是因为Corroflon内壁“螺旋角”的度数为80-120度, 而传统螺旋软管的角度为45-65度, 这使得Corroflon的螺旋幅度更小, 有利于增强介质流速。

其次, Corroflon是市场上所见到的螺旋PTFE软管中唯一可以在高温高压情况下能做到耐完全真空、耐扭结的软管。这是因为Corroflon软管外层增加一个高强度螺旋钢丝, 是的软管强度更高, 同时有保持了软管最佳的柔韧性和易清洁性。在扣压总成时, 将螺旋钢丝焊接在两端接头上, 既保证软管的可靠性又可以确保静电的疏导。

第三, 只有Aflex能保证1寸以上的软管壁厚不低于1.5MM, 这就使得软管能够提供足够的强度来承受来自内部的压力, 使得“正弦波式压力”不至于转换成“方波式压力”, 从而避免软管由于穿孔而被损坏。另外, 这种比较厚的内衬PTFE层也使得软管的气密性更好, 也便于总成的翻边, 更有利于流体在流经接头处的不间断性。

Corroflon GP PTFE Hose

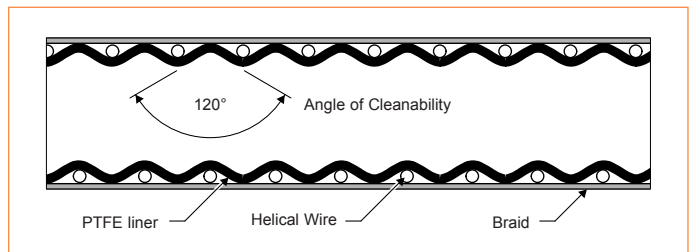

Typical Convoluted PTFE Hose

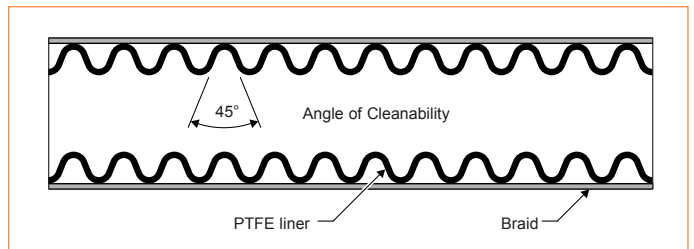

Corroflon GP, SS Hose and PTFE Lined Flange Fitting

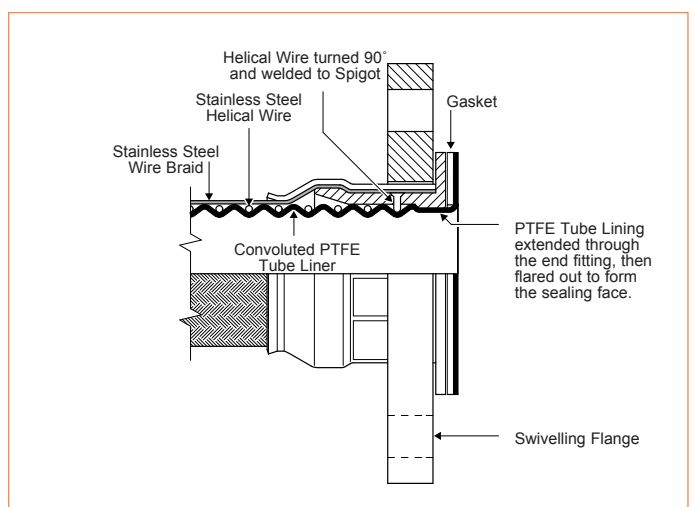

最大工作压力 (MWP) 温度变化曲线图：

不锈钢编织软管相关数据如右图。

PB编织软管在-30 至80 范围内的压力详见第10页，80 至100 的压力参考上述压力值的50%即可。

有橡胶层、防火层和硅胶层的软管MWP温度变化图也请参考右图，但是此压力数据值是在其耐温范围内测得的，详细耐温范围见下。

最大耐温范围 (针对内部介质的温度)

SS -73 °C to +260 °C

PB -30 °C to +100 °C

SS,RC & SS, FP -40 °C to +140 °C

SS, SI -73 °C to +204 °C

KYB -40 °C to +120 °C

(软管外壁所耐受的温度可以参考上面的温度然后减去20 °C)

Temperature & MWP Graph for Corroflon GP, SS and AS, SS

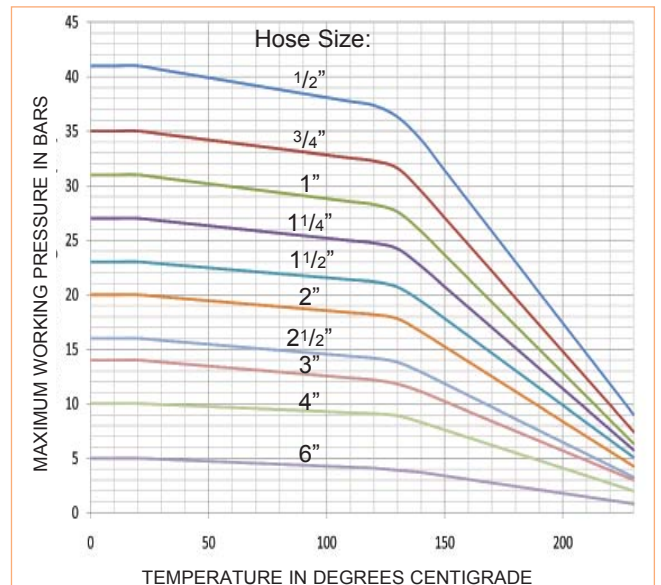

温度与耐真空性

2寸一下，所有尺寸的Corroflon钢丝编织管 (GP/SS和AS/SS)，在130 °C下都实用完全真空，高于130 °C时每升高一度抗性降低1%。

其他类型的软管也一样，但必须要在其耐温范围内。

Bioflex软管流速计算方式

如果需要对特定软管总成进行流速设定，或者需要对特定压力介质设定一个流速值，我们会根据你们所提供的信息进行必要的大概计算。

Corroflon软管介质流速计算方式：

如下信息你们需要提供给我们：

为了计算单位时间内的流速情况 (立方米/小时) 需要提供：

-总成进口处的压力值 (BAR)

两项相减就是软管总成两端的压力差

-总成出口出的压力值 (BAR)

-软管的摆放方式 (平直, 33%最小弯曲半径, 66%最小弯曲半径, 完全卷曲)

为了计算软管总成内部的压力差变化，需要提供：

-总成每小时流出的介质立方数

-软管的摆放方式 (平直, 33%最小弯曲半径, 66%最小弯曲半径, 完全卷曲)

无噪音

输送蒸汽或其他气体时，气体在通过螺旋管过程中会发出“口哨”噪声，如果有这方面的顾虑我们推荐使用Bioflex软管就可完全除此问题。

Corroflon Sizes, Grades, Bend Radius and Dimensions

Nominal Hose Bore Size		Bore Inside Convolutions		Corroflon Grade (Braid & Cover)	PTFE Liner Tube Wall Thickness		O/D of Tube, Braid or Rubber		Minimum Bend Radius		Maximum Continuous Hose Length	
in	mm	in	mm		in	mm	in	mm	in	mm	Feet	Metres
1/2	15	0.440	11.2	TO	0.05	1.4	0.63	16.0	1 1/2	38	92	28
				SS			0.69	17.5	1 1/2	38	92	28
				PB			0.75	19.1	1 1/2	38	92	28
				SS,RC/FP			0.92	23.5	2 1/4	57	92	28
				RC,SI			0.92	23.5	2 1/4	57	92	28
				KYB			0.75	19.1	1 1/2	38	92	28
3/4	20	0.620	15.7	TO	0.05	1.4	0.84	21.4	2	51	100	30
				SS			0.91	23.1	2	51	100	30
				PB			1.02	26.0	2	51	100	30
				SS,RC/FP			1.17	29.6	3	76	100	30
				RC,SI			1.17	29.6	3	76	100	30
				KYB			1.02	26.0	2	51	100	30
1	25	0.847	21.5	TO	0.06	1.5	1.16	29.4	2 3/4	70	130	40
				SS			1.25	31.7	2 3/4	70	130	40
				PB			1.34	34.0	2 3/4	70	130	40
				SS,RC/FP			1.56	39.7	4 1/4	105	130	40
				RC,SI			1.56	39.7	4 1/4	105	130	40
				KYB			1.34	34.0	2 3/4	70	130	40
1 1/4	32	1.080	27.5	TO	0.06	1.5	1.47	37.0	3 1/4	82	100	30
				SS			1.50	38.4	3 1/4	82	100	30
				PB			1.72	43.6	3 1/4	82	100	30
				SS,RC/FP			1.69	42.8	4 3/4	123	100	30
				RC,SI			1.69	42.8	4 3/4	123	100	30
				KYB			1.72	43.6	3 1/4	82	100	30
1 1/2	40	1.250	32.0	TO	0.06	1.5	1.68	42.7	4	100	82	25
				SS			1.76	44.6	4	100	82	25
				PB			1.91	48.6	4	100	82	25
				SS,RC/FP			2.22	55.8	6	150	82	25
				RC,SI			2.22	55.8	6	150	82	25
				KYB			1.91	48.6	4	100	82	25
2	50	1.690	43.0	TO	0.07	1.8	2.22	56.5	5 1/2	140	60	18
				SS			2.32	59.0	5 1/2	140	60	18
				PB			2.44	62.0	5 1/2	140	60	18
				SS,RC/FP			2.68	68.0	8 1/4	210	60	18
				RC,SI			2.68	68.0	8 1/4	210	60	18
				KYB			2.44	62.0	5 1/2	140	60	18
2 1/2	65	2.120	54.0	TO	0.07	1.8	2.80	71.0	7	178	43	13
				SS			2.88	73.0	7	178	43	13
				PB			3.03	77.0	7	178	43	13
				SS,RC/FP			3.11	79.0	10 1/2	267	43	13
				RC,SI			3.11	79.0	10 1/2	267	33	10
				KYB			3.03	77.0	7	178	43	13
3	80	2.500	64.0	TO	0.07	1.8	3.30	83.6	9	230	33	10
				SS			3.39	86.0	9	230	33	10
				PB			3.55	90.0	9	230	33	10
				SS,RC/FP			3.74	95.0	13 1/2	345	33	10
				RC,SI			3.74	95.0	13 1/2	345	33	10
				KYB			3.55	90.0	9	230	33	10
4	100	3.860	98.0	TO	0.08	2.0	4.50	114.0	11 3/4	300	16	5
				SS			4.61	117.0	11 3/4	300	16	5
				PB			4.73	120.0	11 3/4	300	16	5
				SS,RC/FP			4.85	123.0	17 3/4	450	16	5
				RC,SI			4.85	123.0	17 3/4	450	16	5
				KYB			-	-	-	-	-	-
6	150	5.250	130.0	TO	0.10	2.5	6.30	160.0	23 3/4	600	13	4
				SS			6.70	170.0	23 3/4	600	13	4
				PB			-	-	-	-	-	-
				SS,RC/FP			6.93	176.0	35 1/2	900	13	4
				RC,SI			6.93	176.0	35 1/2	900	13	4
				KYB			-	-	-	-	-	-

Corroflon Sizes, Grades, Pressure Ratings & Weights

Nominal Hose Bore Size		Bore Inside Convolutions		Corroflon Grade (Braid & Cover)	Maximum Working Pressure of Hose		Burst Pressure		Weight per Unit Length	
in	mm	in	mm		Bar	psi	Bar	psi	Kg/Mtr	lb/ft
1/2	15	0.440	11.2	TO	6	87	24	350	0.21	0.14
				SS	41	595	450	6525	0.33	0.22
				PB	31	450	150	2175	0.26	0.17
				SS,RC/FP	41	595	450	6525	0.49	0.33
				RC,SI	41	595	450	6525	0.49	0.33
				KYB	15	215	61.5	890	0.23	0.15
3/4	20	0.620	15.7	TO	5	70	20	290	0.29	0.19
				SS	35	505	240	3480	0.45	0.30
				PB	26	375	105	1520	0.36	0.24
				SS,RC/FP	35	505	240	3480	0.56	0.38
				RC,SI	35	505	240	3480	0.56	0.38
				KYB	13	190	52.5	760	0.31	0.21
1	25	0.847	21.5	TO	4.5	65	18	260	0.45	0.30
				SS	31	450	200	2900	0.70	0.47
				PB	23	334	93	1350	0.56	0.38
				SS,RC/FP	31	450	200	2900	0.98	0.66
				RC,SI	31	450	200	2900	0.98	0.66
				KYB	11	160	46.5	675	0.49	0.33
1 1/4	32	1.080	27.5	TO	4	58	16	230	0.53	0.36
				SS	27	390	180	2610	0.82	0.55
				PB	20	290	81	1175	0.66	0.44
				SS,RC/FP	27	390	180	2610	1.12	0.75
				RC,SI	27	390	180	2610	1.12	0.75
				KYB	10	145	40.5	585	0.57	0.38
1 1/2	40	1.250	32.0	TO	3.5	50	14	205	0.97	0.65
				SS	23	335	120	1740	1.50	1.01
				PB	17	245	69	1000	1.20	0.80
				SS,RC/FP	23	335	120	1740	1.90	1.27
				RC,SI	23	335	120	1740	1.90	1.27
				KYB	9	130	34.5	500	1.05	0.70
2	50	1.690	43.0	TO	3	44	12	175	1.36	0.91
				SS	20	290	100	1450	2.10	1.41
				PB	15	215	60	870	1.68	1.13
				SS,RC/FP	20	290	100	1450	2.72	1.82
				RC,SI	20	290	100	1450	2.72	1.82
				KYB	8	115	30	435	1.47	0.99
2 1/2	65	2.120	54.0	TO	2.5	36	10	145	1.68	1.13
				SS	16	230	70	1015	2.58	1.73
				PB	12	175	48	695	2.06	1.38
				SS,RC/FP	16	230	70	1015	3.10	2.08
				RC,SI	16	230	70	1015	3.10	2.08
				KYB	6	87	24	350	1.81	1.21
3	80	2.500	64.0	TO	2	29	8	115	2.14	1.43
				SS	14	205	60	870	3.29	2.20
				PB	10	145	42	610	2.63	1.76
				SS,RC/FP	14	205	60	870	3.95	2.65
				RC,SI	14	205	60	870	3.95	2.65
				KYB	5	73	21	305	2.30	1.54
4	100	3.860	98.0	TO	1.5	22	6	87	3.18	2.13
				SS	10	145	40	580	5.05	3.38
				PB	8	115	30	435	3.98	2.67
				SS,RC/FP	10	145	40	580	6.12	4.10
				RC,SI	10	145	40	580	6.14	4.11
				KYB	-	-	-	-	-	-
6	150	5.250	130.0	TO	0.75	11	3	44	6.50	4.36
				SS	5	73	20	290	10.00	6.70
				PB	-	-	-	-	-	-
				SS,RC/FP	5	73	20	290	12.00	8.04
				RC,SI	5	73	20	290	12.00	8.04
				KYB	-	-	-	-	-	-

清洗与灭菌系统-CIP,SIP和高压锅灭菌

CIP和SIP-PTFE内衬软管的化学抗性非常好，可以耐受所有的CIP,SIP和高压锅灭菌过程，你所有考虑的只有一件事：有可能，软管内衬会在清洗过程中产生静电影响软管使用，如果需要消除此影响，可以采用AS抗静电软管。

AS软管和静电生成原因在介绍软管内衬时已详细介绍，请参考。

使用高电阻介质来进行CIP操作时，比如介质为甲苯，需要采用AS软管。

另外容易产生静电的情形是：在清洗过程中，清洗介质为湿蒸汽或清洗溶剂（WFI）经由氮气、压缩空气或其他气体来推动时，由于液体与气体不能相溶，这样就产生一个“多级性”混合介质，这就很容易产生静电，这样的过程一般推荐使用AS软管。

如果你的使用环境容易产生静电，但是又不愿意采用黑色的PTFE软管内衬，我们还有替代方式，请咨询我们。

高压灭菌-高压灭菌一般没有高速流动的介质，所以不会有静电的产生顾虑。不锈钢编织SS或HB哈氏合金编织的Aflex软管（GP和AS）都是可以完全适应高压灭菌使用条件。EPDM橡胶包覆、硅胶包覆的软管一般都可以承受100次30分钟的高压灭菌过程，在其相应的灭菌温度（121 °C或135 °C），特定的使用要求，请咨询Aflex。

碱金属、卤素、卤化物输送：

PTFE容易与氟气、三氯化氯和熔融状态的碱金属反应，不能用PTFE软管输送上述物质。当用内衬PTFE软管输送氯、溴（气体或液体）时，介质会透过软管内衬PTFE层。泄漏出来的很微量的此类物质很容易与周围空气中的水分结合后腐蚀外编织层和橡胶包覆层。重卤素化合物，比如氯化氢、氟化氢、光气（碳酰氯）、四氯化碳和其他高含量卤素有机化合物都容易被PTFE管壁吸收并渗透到管外壁。

其他渗透性强的液体与气体：

三氧化硫,甲基丙烯酸甲酯,己内酰胺和冰醋酸等也都被PTFE管壁吸收并渗透到管外壁。

不过PTFE材作为一种疏水性（不容易吸收水）材料，一般情况下对这些化合物的抗性都非常好。在某些特殊的场合下，PTFE的对易于挥发的物质有很好的防扩散性能，比如输送汽车燃油，PTFE软管比其他塑料或橡胶软管都要适合。

气体/液体循环应用：

在某些应用中：软管时而通液体时而又换成气体，周期往复。这种情况下，软管所输送介质的温度和压力都会影响软管的使用寿命，无论软管是什么材质的，在某些复杂的输送条件下软管内衬很容易损坏。比如，软管被用于间歇性的输送热蒸汽和水，橡胶层在和内衬很容易在冷热交替进行的输送过程中损坏，PTFE内衬软管也不列外。

总成用作连接部件：

如果总成被用于两个系统的连接部件，总成的长度和它的相关配件构造都要符合下文将要介绍的“软管连接配置说明”。这种情况下，总成的接头的配件一定要正确装配，用正确的工具、扳手、螺母和螺栓来固定。连接总成一定要完美的固定住，保证不会有泄漏发生，但是又不能固定的过紧而损坏密封垫圈等。

在用于输送昂贵或者危险性高非常高的流体或气体时，软管和用作连接的总成一定要在实地进行压力测试，可以用无毒害的介质，在1.5倍最大工作压力下进行检测。

特殊用途：

- Aflex PTFE内衬软管对下述应用情况并不适合：
 - 所有放射性应用，包括高能辐射、伽马射线（会使得PTFE分解）
 - 所有医疗移植应用
 - 所有航空航天行业应用
 - “无硅胶”应用：

在某些应用中，比如说油漆厂或其他一些特定的场所：需要软管在生产环节不能添加硅胶成分（可以实现），或者做到100%不含有一点硅胶成分（不容易做到），就需要考虑使用别的产品来替代。这对于客户和分销商来说必须要搞清楚，然后在下单的时候告诉我们。

Bioflex软管质量认证与检测

BS EN ISO 9001 : 2008

Aflex所有产品的生产都严格遵循BS EN ISO 9001 : 2008质量管理体系，都在NQA（国家质量保证部）注册、评估过。

USP CLASS VI 和ISO 10993-5, 6, 10, 11指南

GP（一般PTFE）和AS（抗静电PTFE）级内衬PTFE材质、铂金硫化硅胶层（白色和透明）、蓝色EPDM都各自依据USP规范协议做过检测，检测结果符合USP CLASS VI <88>的规范要求。

GP（一般PTFE）和AS（抗静电PTFE）级内衬PTFE材质、铂金硫化硅胶层（白色和透明）按照USP相关协议进行检测后确认符合UPS CLASS VI <87>规范要求，经过L929 MEM ELUTION检测后确认无细胞毒性。

FDA

软管所有内衬PTFE材质都符合FDA 21 CFR 177.1550标准，抗静电PTFE材质符合FDA 21 CFR 178.3297标准。

3-A 卫生级标准

生产软管所需的PTFE材料从原料到生产完全符合3-A卫生级标准。

知名医药公司的获准

全球大多数知名医药生产公司都已经批准Aflex作为其软管/总成的供应商。

USP<661> 塑料制品物理化学测试

GP（一般PTFE）和AS（含炭黑）内衬PTFE材质外螺旋、内平滑PTFE软管依据USP针对塑料制品所规定的物理化学测试要求进行检测后确认其符合：USP34, NF 29, 2011.

Monograph <661> Containers, Physicochemical Test-Plastics

BPSA 析出物检测

Aflex所提供的软管内衬（GP/AS）PTFE软管都分别依据BPSA指导方法进行了实验检测，结果满足其要求。

具体的检测评估报告复印件可以提供给客户。

CE标识（仅限欧盟）

Aflex软管已经通过苏黎世工程部评估，确认软管总成符合97/23/EC（欧盟）评估模块D1中就设备压力的规范要求，被授权可以在产品上使用CE标识，可配合软管数据表和合格声明一起发布使用。

ATEX 94/9/EC指令认证（具有爆炸危险的气体）

软管、总成及其各组件适用于Gas Zones 1 & 2和Dust Zones 21 & 22

EN10204材质认证

适用我们所有的软管和软管总成组件

BS EN ISO/IEC 17050认证

适用于我们所有的产品

软管总成测试

每一根总成在出厂前都需要在1.5倍最大工作压力下的压力测试，并且会出具检测报告BS5173 103.13章节的6.2-6.3部分关于防火标准

外包橡胶Corroflon软管总成是符合“防火”标准的，如果总成两端有DRC-300（双橡胶包覆）“防火”效果更好。

How to Order Corroflon Hose Assemblies

How to Order

The quantity, hose size, liner, braid, cover, protection system, length and fittings must be selected and specified in full.

EITHER by a full, written description. The hose grade can be specified by the code initials e.g. "Corroflon AS, SS, RC, DRC-300" defines an antistatic PTFE lined hose with an EPDM rubber cover over a SS braid, with a double rubber cover at both ends.

The quantity, length and fittings can then be written in - e.g. "4 off x 1" bore Corroflon, AS, SS, RC, DRC-300 hose x 3.00 metres long (10ft). Both ends non-lined ANSI 150# S/S Flanges".

OR by Part Numbers, as defined on page 11.

Any special requirements relating to the hose construction, or information required on Tags, or Certificates, or special testing of requirements, must be specified in full on the enquiry or purchase order.

Selecting the Hose Grade

PTFE Liners include, Standard (GP) or Special Purpose (SP), both available either in natural white PTFE or in black, Antistatic PTFE (AS). There are four types of braid, Grade 304 stainless steel (SS) polypropylene (PB), Hastelloy (HB), PVDF or Kynar (KYB). These are described on pages 12 & 13. Rubber covering and other external protection systems are also available, described on page 14.

A hose grade is specified by using the abbreviations given. For example, Bioflex AS,PB would describe a hose with an anti-static PTFE liner and a polypropylene braid.

Note: Most of the sizes of hose and fittings listed in this brochure are available as ex-stock items and are priced accordingly. However, when certain items have not been purchased in the last 12 months, they are no longer held in stock, and are only available to Special Order.

Aflex Hose will advise accordingly when enquiries are placed for these items.

Selecting the Hose Length (see also pages 33 - 35)

Corroflon hose assemblies are made up to the specific lengths required. The hose length is taken as the length from the sealing face at one end of the hose to the same at the other end. The length tolerance is normally +10% -0% for lengths more than 1 mtr, and +5%-0% for lengths up to 1 mtr. Closer tolerances are available to special order.

Corroflon Hose Assembly Length Limitations									
Nominal Size of Hose		*Minimum Hose Assembly Length						Maximum Hose Assembly Length	
		Used Straight		Minimum at MBR					
		All Types		TO, SS, PB, KYB		RC			
in	mm	in	mm	in	mm	in	mm	ft	mtrs
1/2	15	3	75	2.36	60	3.54	90	91	28
3/4	20	3	75	3.19	81	4.72	120	98	30
1	25	3	75	4.33	110	6.50	165	131	40
1 1/4	32	3	75	5.08	129	7.64	194	98	30
1 1/2	40	3	75	6.22	158	9.29	236	82	25
2	50	3	75	8.66	220	12.99	330	60	18
2 1/2	65	4	100	11.02	280	16.54	420	43	13
3	80	4	100	14.25	362	21.34	542	32	10
4	100	12	300	18.58	472	27.83	707	16	5
6	150	12	300	37.13	943	55.67	1414	14	4

* Listed minimum lengths are for the Corroflon Hose only, and **DO NOT INCLUDE THE LENGTHS OF THE FITTINGS AT EACH END.** These must be found from the end fitting pages and added to calculate the minimum length of the hose assembly.

Used straight with fittings in line.

Only minimal vibration permitted.

Selecting the End Fittings

Corroflon is available with a range of 'standard' end fittings (described on pages 15-32), both integral PTFE lined and non-lined

Stainless Steel End Fitting Materials

Non-Lined Spigots - are all made from Grade 316L SS

PTFE Lined Spigots - are all made from Grade 316L or Grade 316C SS

Cam and Groove Female Fittings - are made from Grade 316C SS (Body) and 316L SS (Spigot)

Swivelling Nuts and Flanges - are all made from Grade 304 SS

Ferrules - most ferrules are made from Grade 304 SS, except some are made from Grade 316L SS - consult Aflex Hose if necessary.

The equivalent specification for the different Grades of Stainless Steel are listed below:

Grade	BS - British Standard	AISI - American Standard or C = Casting Grade	EN - European Norm
316L SS	BS 316 S11	AISI 316 L	EN 1.4404
316C SS	BS 316 C16	CF8M	EN 1.4408
304 SS	BS 304 S15	AISI 304	EN 1.4301

Conditions of Sale

Corroflon hose and hose assemblies are only supplied on the basis that the customer has read and accepted the Conditions of Sale as given at the end of this brochure and on the Aflex Hose website.

Corroflon Hose Assembly Part Number System

If required, Corroflon Hose Assembly can be defined by an individual Part Number, made up of (7) entries as below:

1	Hose Size	Size Part No.
	1/2"	08
	3/4"	12
	1"	16
	1 1/4"	20
	1 1/2"	24
	2"	32
	2 1/2"	40
	3"	48
	4"	64
	6"	96

2	Hose Type	Type Part No.
	Corroflon GP (Natural PTFE Liner)	CFLN/GP
	Corroflon AS (Antistatic PTFE Liner)	CFLN/AS

3		Braid and Cover
	Tube Only	TO
	Stainless Steel Braid	SS
	Polypropylene Braid	PB
	Hastelloy Braid	HB
	Kynar (PVDF) Braid	KYB
	Black EPDM Rubber Cover (on SS)	RC
	Transparent Silicone Rubber (on SS)	SI
	Red Fireproof EPDM Rubber (on SS)	FP

4		External Protection Systems
	No External Protection System	OO
	SS Wire Protection Coil	PC
	Rubber Anti-Scuff Rings	SR
	'Safeguard' HDPE Spiral Wrap	SG

5	Length
	The overall hose length between the sealing faces at each end is given as the Length Part No, either in decimal Metres followed by "m" or Inches followed by "in".

6 & 7	Assembled End Fitting Description *All Components in Stainless Steel	End Fitting Part No.
	JIC Female	02
	Fixed Male Pipe, NPT Thread	03
	Fixed Male Pipe, BSPT Thread	03/B
	Fixed Female Pipe, NPT Thread	06
	JIC-to-NPT Male Union	08
	JIC-to-Female Male Union	08F
	Straight Sanitary Tri Clamp, 1.984" Diameter 0.870" Exit Diameter (Standard) 1.370" Exit Diameter (Step-Up)	10 10/S
	Straight Mini Sanitary Tri Clamp, 0.984" Diameter 0.370" Exit Diameter (Standard) 1.620" Exit Diameter (Step-Up)	11 11/S
	*ANSI 150# Swivelling Flange Non-Lined	12
	DIN PN 10/16 Swivelling Flange Non-Lined	12/PN
	*ANSI 150# Swivelling Flange, PTFE Lined	12L
	DIN PN 10/16 Swivelling Flange, PTFE-Lined	12L/PN
	Cam and Groove, Locking Arm Swivelling Female, Non-Lined	16
	Cam and Groove Locking Arm Swivelling Female, PTFE Lined	16L
	Cam and Groove Male, Non-Lined	17
	Cam and Groove Male, PTFE Lined	17L
	DIN 11851 Female, PTFE Lined	23L
	DIN 18851 Male, PTFE Lined	24L
	SMS Female, PTFE Lined	26L
	RJT Female, PTFE Lined	27L
	BSPP Cone Seat Female	33
	BSP Lug Nut Female	34

*For flange only, Carbon Steel Zinc Plated, add "/ZP" or Epoxy coated add "/EC"

Notes: ELBOWS - Elbow Fittings for all types are indicated by adding "/90" for 90° elbows.

TRICLAMPS: For "Hot Formed" PTFE Lined Triclamps add "/HF"

Example: a 3/4" bore Corroflon GP, RC Hose Assembly with an Antistatic PTFE Liner and an outer Safeguard sleeve.

End (1) - a 3/4" ANSI 150# Swivel Flange, PTFE Lined

End (2) - a Cam and Groove Swivelling Female, PTFE Lined

Length - 4ft 6 inches

Hose Assembly Part No. = 12 - CFLN/AS - RC - SG - 54in - 12L - 16L

(1) (2) (3) (4) (5) (6) (7)

ADDITIONAL REQUIREMENTS

Any additional requirements which are not included in the Part Number must be written out in full in the Order, including any special labelling or colour coding

* **Note** - if one of the rubber end protection systems is required, for one or both ends, please define the requirement in writing in addition to the Part Number.

GP-一般用途PTFE



目的：

Corroflon GP/SS软管是一般用途软管，被设计用于满足最广泛的应用需求。

设计特点和符合标准：

软管内衬由符合FDA 21 CFR 177.1550标准的PTFE挤压、螺旋成型，管外壁螺旋内嵌入一根304不锈钢丝，给软管更好的保护，显著提高软管耐受内部压力和外部摩擦性能。

Corroflon GP软管内衬在121 ° C下符合USP CALSSS VI标准，详见 9页。

SP - Special Purpose Liner



Purpose

For applications requiring a higher temperature/pressure rating, greater flexibility and improved kink and crush resistance. Also for applications requiring full vacuum resistance for hose sizes larger than 2".

Design

The convolutions are closer together, yielding greater radial strength to the hose design.

Specifications

As for Corroflon GP, except that the maximum working pressure for wire braided grades is increased by 25%, the weight per metre is increased by 30%, the actual through bore is reduced by 1/8" (3mm), the maximum continuous length is reduced by 50%, the minimum bend radius is reduced by 25% and the angle of cleanability is <80°.

Available as SP (Natural) and SP, AS (Antistatic) Grades.

AS-抗静电PTFE



目的：

Corroflon AS (抗静电) 软管主要设计用于对静电释放存在危险的应用场合，软管内的介质在通过软管的过程中会产生静电荷，静电荷的积聚很容易对外放电引发危险。特别是对某些电导率小于10-8S/M或104PS/M的介质，诸如燃油、有机溶剂、氟利昂、注射用水（超纯水）和某些无极性有机物，在高速通过软管的过程中很容易产生静电荷。

所有双极性或多级性介质和不相容介质（比如含有粉尘的空气、含有水珠的蒸汽、普通气体或油、胶状流体）都容易产生静电，用于输送这些介质时需要使用AS抗静电软管。

一个典型的应用实例就是在清洗系统中，双极性混合物（WFI与空气或氮气混合）高速通过软管一般要用到此类软管。

如果还有疑问，请与我司联系。

设计要求与标准：

Corroflon AS抗静电PTFE内衬软管是由符合FDA 21 CFR 177.1550标准的PTFE材质生产出来的，软管中添加的2.5%的“高纯度”炭黑材料符合FDA 21 CFR 178.3297的标准。这些炭黑完全被PTFE分子包裹，一般情况下（无摩擦）不会剥离出来污染所输送的介质（这一点已经在依据BPSA规范进行析出物检测中得到证实）。

Corroflon AS 软管内衬在121 ° C下符合USP CLASS VI标准。

抗静电软管总成

一般情况下，如果应用中需要抗静电（AS）处理，软管和软管总成就需要进行测试，软管需要符合EN ISO 8031：2009的标准，达到此项标准附录A的抗静电要求。此标准要求针对软管内衬层和外覆层，金属接头与软管任意两个电极之间的电阻都必须介于103-108 ohms，对于满足此标准的总成，可以依据EN 1SO 8031：2009附录A的规定在总成的上标注“”标示。

注意：在应用中，至少有个接头需要接地，来消除使用过程中产生的静电荷。

SS-不锈钢编织



不锈钢编织特氟龙软管是常规产品，耐高温高压，高韧性。AISI 304L不锈钢编织给软管更好的保护，也使得软管更耐压。

TO-只有软管（无编织）

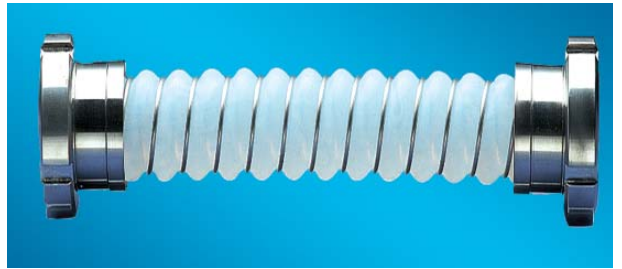

无编织特氟龙软管（GP和AS管都适用）是一款轻型特氟龙软管，一般用于压力比较小、无需外编织防护的场合。

PB-聚丙烯编织



聚丙烯编织软管比不锈钢编织特氟龙软管更适用于需要频繁移动和手动操作的场合，不过要求工作温度在-30 °C至100 °C之间。聚丙烯编织质量轻，而且即使编织层有破裂也不会伤到操作员的手，更安全。另外，聚丙烯编织耐“氯化物腐蚀”，有更好的化学抗性。

注意：PB编织如果长时间暴露在阳光下，紫外线会导致PB材料的降解。

HB-哈氏合金编织



如果软管使用的外部环境中存在强腐蚀性物质，可以选用哈氏合金编织特氟龙软管替代不锈钢编织特氟龙软管。最常用到此软管的是用于输送氯、溴、氟化氢、硫化氢和光气等。因为微量的上述物质（液态或气体）可能透过管壁扩散到管壁外，并与空气中的水分反应很容易破坏软管的编织层，哈氏合金在60 °C以下可以有效抵御此类侵蚀。

关于此软管的具体应用需要咨询AFELX，我们会给你们评估和建议。

规格：

尺寸等规格和SS 不锈钢编织特氟龙软管一样，详见7页，不过哈氏合金特氟龙软管爆破压力和最大工作压力要比不锈钢编织特氟龙软管要低50%。

KYB-聚偏氟乙烯编织



聚偏氟乙烯编织（KYB）特氟龙软管和哈氏合金编织（HB）特氟龙软管应用环境类似，但是KYB软管的耐压要比HB小很多。而且此软管一般推荐定制一个保护外套来配套应用，哈氏或蒙乃尔合金钢丝一般配合应用。

关于此软管的具体应用需要咨询AFELX，我们会给你们评估和建议。

SPECIAL NOTE:

**EC - Electrical Continuity
(Also known as “Electrically Bonded”)**

The requirements for this are specified in the German Document BRG 132 and EN ISO 8031:2009 Annex A, when tested in accordance with EN ISO 8031:2009, which requires that the resistance between end fittings shall be $<10^2$ ohms per assembly. For hose assemblies which meet this requirement a Grade “M” marking can be applied in accordance with EN ISO 8031:2009 Annex A if requested.

RC-外包橡胶



此橡胶外层是专门针对使用环境复杂、磨损强度高为实际应用，另外对软管的卫生、外壁光滑、易清洁性等要求比较高也可以选用此软管。

设计特点：

PTFE内衬外边是SS不锈钢编织层，黑色防静电EPDM橡胶通过挤压工艺直接覆盖在编织层上，使得软管外壁非常光滑。

EPDM的化学抗性优异，耐温范围为：-40 °C至140 °C（介质温度）或者120 °C（环境温度）。

“RC-BLUE”表示蓝色（不防静电）EPDM橡胶，这种规格的软管也是可选的，50米以上长度的是挤压成型，小于50米的可以辊轴包覆。

带文字的说明条带、橡胶颜色、文字都可以根据具体要求定制，下单时请注明。

SI-外包硅橡胶



作为外包橡胶的一种，外包硅胶特氟龙软管耐温范围更广：-73 °C至204 °C。硅胶层呈半透明，可以观察到内编织层。

设计特点：

不锈钢编织和平滑外壁，铂金硫化硅胶通过挤压工艺（50米以上）或手工辊轴包覆工艺直接在编织层上硫化成型。

符合标准：

外硅胶层经检测符合USP CLASS VI要求，详见9页。

FP-防火橡胶层



FP也是作为外包橡胶的一个特例，依据BS5173规范的103.13章节第6.2条中关于防火一栏，如果要求软管防火就需要加装此保护层。此规范要求软管总成在最小弯曲半径、最大工作压力（介质为水）且一端处于震动状态下必须耐受1100 °C明火的灼烧15分钟不能有泄漏情况发生。

设计特点：

PF软管也是RC软管的一种，只是用耐火红色EPDM替换了普通蓝色EPDM，黑色、防静电防火橡胶需要在下单时特别说明。

RC-300-长300MM的总成端保护套



目的：

实际应用中，如果软管总成接头处需要弯折的比较厉害，就需要对这个地方进行加固来防止软管扭结而影响软管使用。

设计特点：

长300mm的一层橡胶硫化覆盖在接头套筒和软管一端，此方法可以直接在不锈钢编织软管上实施（RC-300），也可以对外包橡胶的软管进行操作，这样在接头处就形成双层橡胶包覆的效果（DRC-300）。

使用的橡胶一般为黑色防静电EPDM橡胶，假如是防火软管（PF）或包硅胶（SI）软管，我们可以提供相同材质、颜色的橡胶或硅胶来制作。（DFP-300或DSI-300）

局限性：

不能对PB编织、KYB编织的软管进行此项操作，如果需要我们对PB编织软管应用此技术，请咨询我们，我们可以提供一个EPR系统供选择（一根300MM长的独立橡胶软管被扣压在总成套筒下边）

Corroflon External Protection Systems

SG - Safeguard Protection Sleeve



Purpose

To protect the hose against external abrasion and mechanical damage. For use in applications where maximum external protection is required with minimum extra hose weight. Particularly useful with PB or KYB hose, where a rubber cover is not an option.

Design

A lightweight black, HDPE (High Density Poly Ethylene) strip spirally wound around the outside of the hose over its whole length, secured to each end fitting by crimping under a SS ferrule.

Limitations

Safeguard is applicable to all hose types and all hose sizes from 1/2" up to 4".

Safeguard is limited to use within a temperature range from -40°C (-40°F) up to +100°C (212°F). Internal fluid temperatures up to 120°C (250°F) are acceptable, when external temperatures are ambient.

The minimum hose assembly length must be doubled, if Safeguard is being used and the maximum assembly lengths for all sizes are capped at 20 metres (65 feet).

The other hose usage limitation specifications are not altered by the addition of Safeguard.

SR - Scuff Rings



Purpose

For medium duty applications where the hose requires some protection against abrasion when dragged over the ground, but where a full rubber cover would be too heavy and cumbersome. Also for PB and KYB braided hose, which cannot be Rubber Covered.

Design

Specially moulded abrasion resistant rubber scuff rings are placed every half metre along the hose.

Limitations

Available for hose sizes 1" (25mm) to 2" (50mm) only. The operating temperature should not exceed 140°C (284°F) (internal).

PC - Protection Coil



Purpose

For applications where the hose requires protection against abrasion when dragged over the ground, but where any rubber reinforcement is not permissible due to temperature, chemicals etc.

Design

A stainless steel wire helix is wound onto the braid and welded to the ferrules at each end.

Limitations

Available for all sizes and grades of hose, including rubber covered.

The maximum assembly lengths for all sizes are capped at 20 metres (65 feet).

Specifications

As for the relevant hose grade.

Corroflon Non Lined Swivel Flange Fittings

Flange Specification

- ANSI B16.5 (also ASME B16.5) Class 150# and 300#
- *DIN PN10/16/40 up to 2" size, PN10/16 from 2 1/2" up to 6" size
- JIS 10K
- Other Pressure Ratings and Flange Specifications are also available

*The dimensions for flanges to the different pressure ratings are identical, so they are inter-changeable.

Maximum Pressure Ratings for Flange Fittings

- ANSI 150# = 16 Bar (230 psi), ANSI 300# = 32 Bar (460 psi)
- DIN PN10 = 10 Bar (145 psi), DIN PN16 = 16 Bar (230 psi), DIN PN40 = 40 Bar (580psi)

End Fitting Materials

- Flanges in Grade 304 SS
- Flange Retainers in Grade 316L SS
- Ferrules, most in Grade 304 SS, some sizes in Grade 316 SS



Alternative Options for Flange Component only:

- Zinc Plated Carbon Steel
- Blue Epoxy Coated Carbon Steel

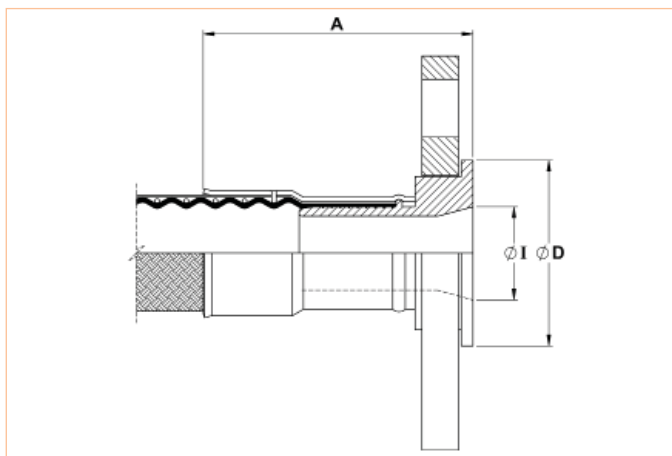

The above drawing relates to sizes 1", 1 1/2", 2"

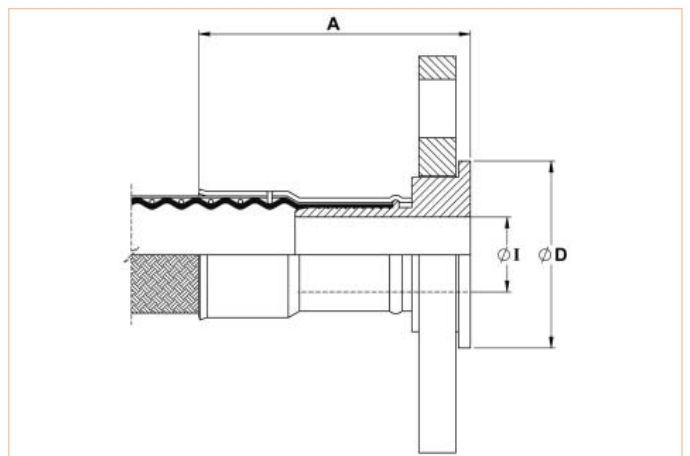

The above drawing relates to all other sizes

Nominal Hose Size		*Fitting Length PN A		Flared Diameter D PN10/16		Fitting Inside Diameter I		Weight of Fitting	
in	mm	in	mm	in	mm	in	mm	Kg	Lbs
1/2	13	2.20	56	1.77	45	0.39	10	0.76	1.69
3/4	20	3.11	79	2.28	58	0.63	16	1.06	2.35
1	25	3.46	88	2.68	68	1.12	28.5	1.36	3.00
1 1/4	32	3.98	101	3.07	78	1.02	26	1.72	3.79
1 1/2	40	4.69	119	3.46	88	1.69	43.10	2.49	5.50
2	50	4.69	119	4.02	102	2.15	54.5	3.57	7.87
2 1/2	65	4.88	124	4.80	122	2.24	57	4.20	9.26
3	80	5.16	131	5.43	138	2.64	67	5.68	12.52
4	100	5.51	140	6.22	158	3.50	89	8.42	18.56
6	150	3.62	92	8.35	212	5.51	140	12.30	27.12

*Fitting Lengths listed are for Corroflon braided only hose grades (SS, PB, HB, KYB). Approximately 33% longer lengths apply to the rubber covered hose grades (RC, SI, FP).

Nominal Hose Size		*Fitting Length ASA A		Flared Diameter D ASA150		Fitting Inside Diameter I		Weight of Fitting	
in	mm	in	mm	in	mm	in	mm	Kg	Lbs
1/2	13	2.13	54	1.37	34.9	0.39	10	0.76	1.69
3/4	20	2.99	76	1.69	42.9	0.63	16	1.06	2.35
1	25	2.95	75	2.00	50.8	0.79	20.24	1.36	3.00
1 1/4	32	3.78	96	2.50	63.5	1.02	26	1.72	3.79
1 1/2	40	4.25	108	2.87	73.0	1.25	31.75	2.49	5.50
2	50	4.41	112	3.63	92.1	1.75	44.45	3.57	7.87
2 1/2	65	4.65	118	4.12	104.5	2.24	57	4.20	9.26
3	80	4.88	124	5.00	127.0	2.64	67	5.68	12.52
4	100	5.51	140	6.19	157.2	3.50	89	8.42	18.56
6	150	3.62	92	8.50	215.9	5.51	140	12.30	27.12

Corroflon Integral PTFE Lined Flange Fittings & "Step-Up" Design

Flange Specification

- ANSI B16.5 (also ASME B16.5) Class 150# and 300#
- *DIN PN10/16/40 up to 2" size, PN10/16 from 2 1/2" up to 6" size
- JIS 10K
- Other Pressure Ratings and Flange Specifications are also available

*The dimensions for flanges to the different pressure ratings are identified, so they are inter-changeable.

Maximum Pressure Ratings for Flange Fittings

- ANSI 150# = 16 Bar (230 psi), ANSI 300# = 32 Bar (460 psi)
- DIN PN10 = 10 Bar (145 psi)
- DIN PN16 = 16 Bar (230 psi), DIN PN40 = 40 Bar (580psi)

End Fitting Materials

- Flanges in Grade 304 SS
 - Flange Retainers in Grade 316L SS
 - Ferrules, most in Grade 304 SS, some sizes in Grade 316L SS
- Alternative options for Flange component only:
- Zinc Plated Carbon Steel
 - Blue Epoxy Coated Carbon Steel.

90° Elbow Flange Fittings (see page 29)

90° Elbow Integral PTFE lined Flange Fittings are available for 1", 1 1/2" & 2".

Integral PTFE Lined Swivel Flange Fittings

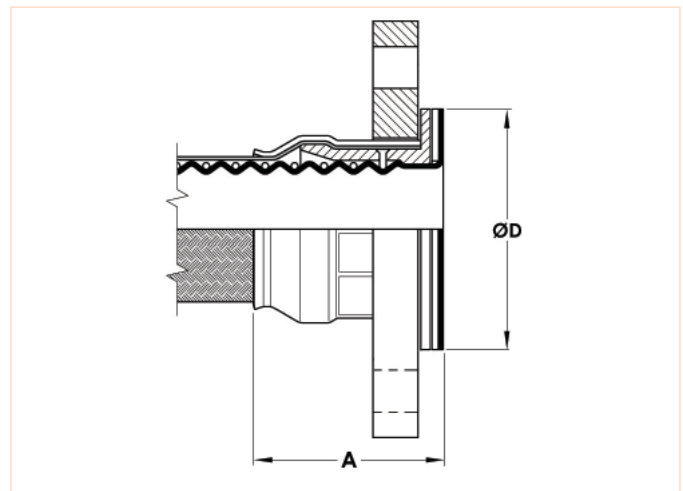

Nominal Size I - Flange & Hose		*Fitting Length ASA A		*Fitting Length PN A		Flared Diameter D		Recommended Bolt Tightening Torques		Weight of Fitting	
in	mm	in	mm	in	mm	ASA150 mm	PN10/16 mm	ft.lbs	Nm	kg	Lbs
1/2	15	2.09	53	2.09	53	32.0	32.0	8	10.79	0.54	1.19
3/4	20	2.28	58	2.34	59.5	43.0	50.0	8	10.79	0.88	1.94
1	25	2.28	58	2.36	60	50.8	63.5	10	13.73	0.96	2.11
1 1/4	32	2.48	63	2.52	64	63.0	78.0	12	16.67	1.36	2.99
1 1/2	40	2.40	61	2.50	63.5	73.0	88.0	15	20.59	1.75	3.85
2	50	2.52	64	2.62	66.5	92.0	102.0	25	34.32	2.70	5.94
2 1/2	65	3.11	79	3.19	81	105.0	122.0	30	41.18	4.00	8.80
3	80	3.11	79	3.11	79	127.0	127.0	40	53.94	5.00	11.00
4	100	5.20	132	5.20	132	158.0	158.0	40	53.94	7.00	15.40
6	150	3.66	93	3.66	93	213.0	213.0	50	67.67	13.00	29.00

*Fitting Lengths listed are for Corroflon braided only hose grades (SS, PB, HB, KYB). Approximately 33% longer lengths apply to the rubber covered hose grades (RC, SI, FP).

*"Step-Up" PTFE Lined Flange Fitting Design for Corroflon Hose

Adapting for Different Flange Sizes

To fit larger than nominal flange sizes

It may be necessary to fit a larger than nominal flange size to the hose - for example, 3" flange fitted to one end of a 2" hose - in which case it may also be necessary to increase the diameter of the sealing face to the correct size for the larger flange. This can be achieved by means of a flange adaptor as shown.

To fit smaller than nominal flange sizes

Within limits, it is also possible to make up an assembly with a flange one size smaller than the nominal size. The smaller flange is bored and fitted to the larger hose and, if necessary, the flared diameter is reduced to suit.

Consult the supplier if a different flange size is required.

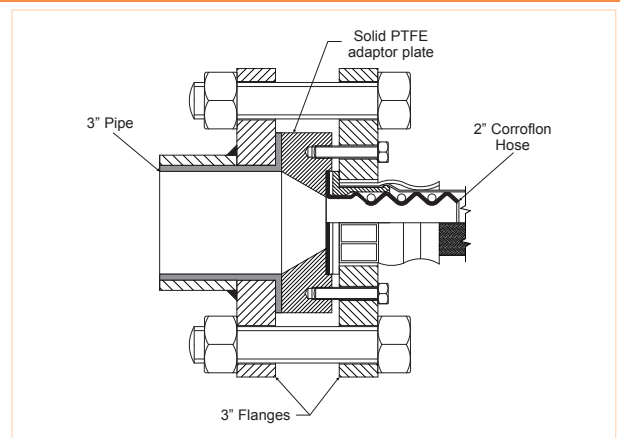

Corroflon Female Cam & Groove Fittings PTFE Lined (Fixed) and Non-Lined (Swivel), Locking Arms

End Fitting Specification

- Generally in accordance with A-A-59326 (replaces MIL-C-27487) and EN14420-7:2004 (replaces DIN 2828), and all are fully interchangeable.

Temperature and Pressure Ratings

- All sizes up to 16 Bar (230 psi)
- Up to 100°C (212°F) Buna N Gasket or 204°C (400°F) FEP Gasket.

End Fitting Materials

- Spigot in Grade 316L SS
- Body in Grade 316C SS
- Ferrules, most in Grade 304 SS, some sizes in Grade 316L SS
- Standard Gasket is Buna N (Nitrile) Rubber.
- FEP encapsulated Silicone Rubber Gaskets also available.

90° Elbow Cam & Groove Fittings (LINED ONLY)

90° Elbow Integral PTFE lined Cam & Groove Fittings are available for sizes 1", 1 1/2" and 2" - see page 29.

Swivelling, Locking Arm Female Cam and Groove Fittings - Non Lined

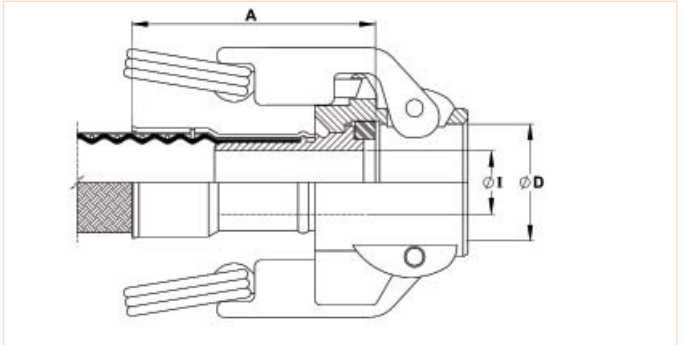
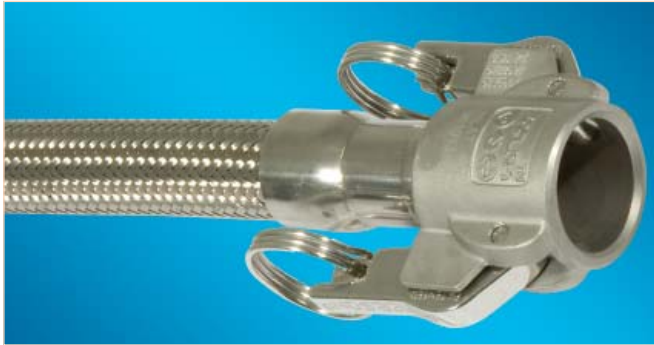

Nominal Hose Size		*Fitting Length A		Cam Sleeve Inside Diameter D		Fitting Inside Diameter I		Weight of Fitting	
in	mm	in	mm	in	mm	in	mm	Kg	Lbs
3/4	19.1	3.11	79	1.26	32	0.63	15.9	0.40	0.88
1	25.4	3.07	78	1.46	37	0.75	19.1	0.51	1.12
1 1/2	38.1	4.13	105	2.13	54	1.25	31.8	0.88	1.94
2	50.8	4.25	108	2.52	64	1.75	44.5	1.15	2.53
2 1/2	63.5	4.49	114	3.03	77	2.25	57.2	1.41	3.10
3	76.2	4.61	117	3.62	92	2.63	66.7	1.89	4.17

*Fitting Lengths listed are for Corroflon braided only hose grades (SS, PB, HB, KYB). Approximately 33% longer lengths apply to the rubber covered hose grades (RC, SI, FP).

Fixed, Locking Arm Female Cam and Groove Fitting - Integral PTFE Lined

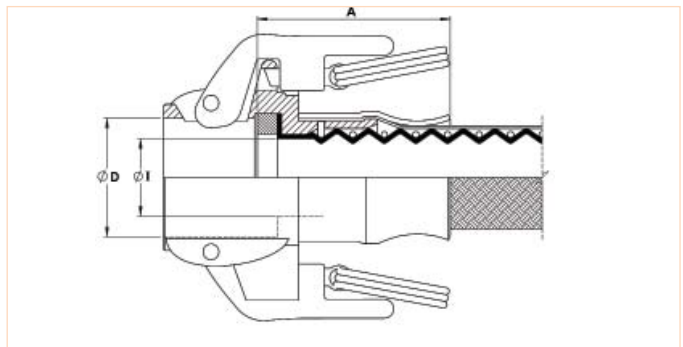

Nominal Hose Size		*Fitting Length A		Cam Sleeve Inside Diameter D		Fitting Inside Diameter I		Weight of Fitting	
in	mm	in	mm	in	mm	in	mm	Kg	Lbs
3/4	19.1	2.48	63	1.26	32	0.70	17.8	0.39	0.86
1	25.4	2.40	61	1.46	37	0.95	24.1	0.50	1.10
1 1/2	38.1	2.56	65	2.13	54	1.44	36.7	0.86	1.89
2	50.8	2.56	65	2.52	64	1.94	49.3	1.10	2.42

Notes: For Integral PTFE Lined Fittings Only

FEP Gaskets require higher clamping forces to flatten the Seal and make the joint. This is made easier by "pre-setting" these gaskets by clamping Polypropylene Cam Male Inserts to the assembled fittings, which must then be kept in place during storage, until use.

Any Customer's Own "Special" Gaskets must be pre-supplied to Aflex for special assembly and testing of hose assemblies, to ensure suitability.

*Fitting Lengths listed are for Corroflon braided only hose grades (SS, PB, HB, KYB). Approximately 33% longer lengths apply to the rubber covered hose grades (RC, SI, FP).

Corroflon Male Cam & Groove Fittings, PTFE Lined & Non-Lined and Flange Adaptors, PTFE Lined

PTFE Lined or Non-Lined Male Cam and Groove Fittings

End Fitting Specification

- Generally in accordance with A-A-59326 (replaces MIL-C-27487) and EN14420-7:2004 (replaces DIN 2828), and all are fully interchangeable.

Temperature and Pressure Ratings

- Temperature determined by the type of gasket in the Female connecting component.
- Pressures up to 16 Bar (230 psi)

End Fitting Materials

- Fittings in Grade 316L SS
- Ferrules, most in Grade 304 SS, some sizes in Grade 316L SS
- Adaptor Flange Only in Grade 304 SS

Integral PTFE Lined Cam & Groove Male Fitting

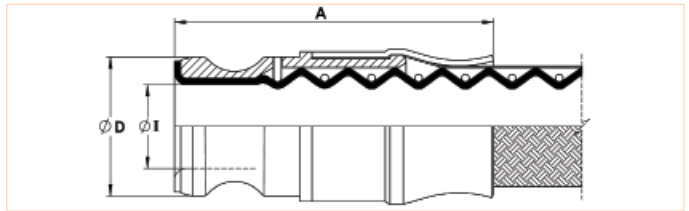

Non-Lined Cam & Groove Male Fitting

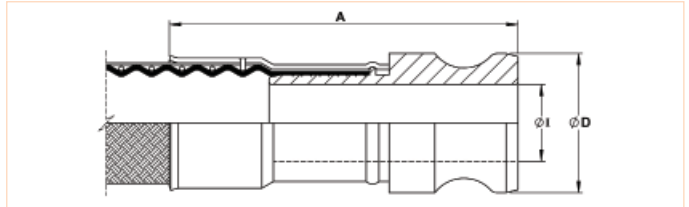

Nominal Hose Size		ØD		Fitting Length A		Non-Lined Inside Diameter I		Lined Inside Diameter B		Weight of Fitting	
in	mm	in	mm	in	mm	in	mm	in	mm	Kg	Lbs
3/4	19.1	1.26	32	3.38	86	0.63	15.88	0.70	17.78	0.40	0.88
1	25.4	1.46	37	3.66	93	0.80	20.24	0.88	22.35	0.49	1.08
1 1/2	38.1	2.13	54.0	5.00	127	1.25	31.75	1.12	28.50	0.81	1.78
2	50.8	2.52	64	5.67	144	1.75	44.45	1.77	44.96	1.05	2.31

*Fitting Lengths listed are for Corroflon braided only hose grades (SS, PB, HB, KYB). Approximately 33% longer lengths apply to the rubber covered hose grades (RC, SI, FP).

PTFE LINED MALE CAM and GROOVE X FLANGE ADAPTORS

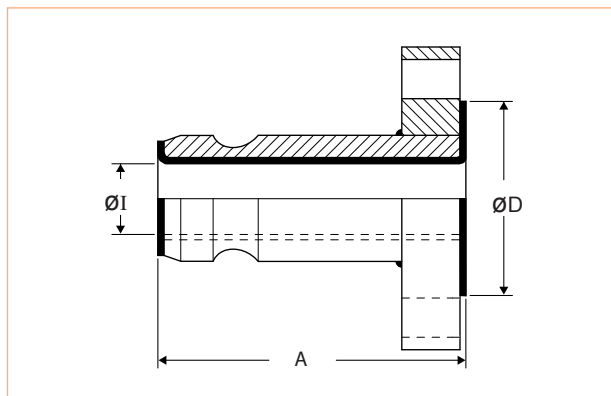

Cam Action Adaptor Size		Flange Size & Specification	ØD		A		I		Weight of Fitting	
in	mm		in	mm	in	mm	in	mm	Kg	Lbs
1	25	1" ANSI/1507	2.00	50	4 1/8	105	0.84	21	1.246	2.75
1	25	DN25/PN16	2.58	64	4 1/8	105	0.84	21	1.538	3.39
1 1/2	40	1 1/2" ANSI/1507	2.87	73	4 3/8	118	1.35	34	2.228	4.92
1 1/2	40	DN40/PN16	3.47	88	4 3/8	118	1.35	34	2.753	6.07
2	50	2" ANSI/1507	3.63	92	4 3/8	118	1.69	43	3.359	7.40
2	50	DN50/PN16	4.02	102	4 3/8	118	1.69	43	3.714	8.19

Note: Other Flange Specifications and Pressure Ratings are also available. Non-Lined adaptors and Female Cam and Groove X Flange Adaptors are also available, to special order.

Corroflon Mini-Sanitary and Sanitary Triclover Fittings - PTFE Lined

End Fitting Specification

- BS4825 Pt 3 (UK)
- ASME BPE-a-2007 (USA)
- DIN32676 (Europe, DN Sizes)
- ISO 1127 (Europe) (Non Standard, Specials Only)

Temperature and Pressure Ratings

- Pressures up to 16 Bar (230 psi)
- Temperatures up to 180°C (356°F)
- Higher Pressures & Temperatures possible with Special Clamps and appropriate Seals.



End Fitting Materials

- Fittings in Grade 316L SS (= BS 316 S11 = EN 1.4404)
- Ferrules, most in Grade 304 SS, some sizes in Grade 316L SS

90° Elbows

PTFE Lined 90° elbow fittings are available for some sizes and grades
- see page 29.

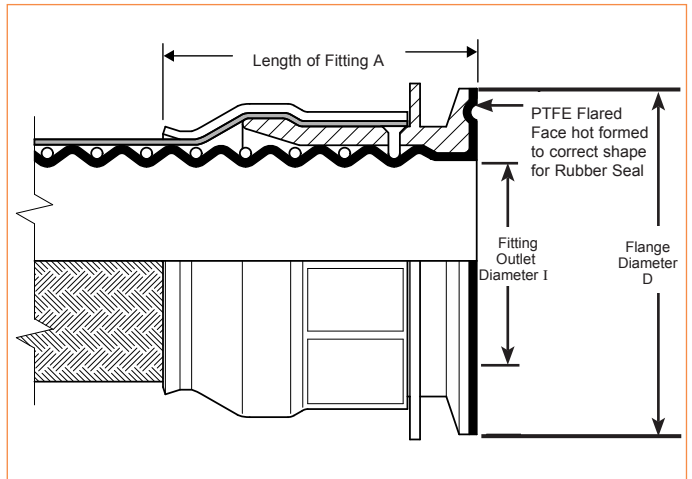

Nominal Hose Size		Nominal Pipe Size		Outlet Diameter I		Flange Diameter D	*Length of Fitting A	Weight of Fitting	
in	mm	in	mm	in	mm	in	mm	Kg	Lbs
1/2	15	1/2	12.7	3/8	9.5	25.0	50	0.075	0.17
1	25	1	25.4	7/8	22.2	50.5	60	0.226	0.50
1 1/2	40	1 1/2	38.1	1 3/8	34.9	50.5	63	0.269	0.59
2	50	2	50.8	1 7/8	47.6	64.0	66	0.407	0.90
2 1/2	65	2 1/2	63.4	2 3/8	60.3	77.5	82	0.510	1.12
3	80	3	76.1	2 7/8	73.0	91.0	82	0.593	1.30

*Fitting Lengths listed are for Corroflon braided only hose grades (SS, PB, HB, KYB). Approximately 33% longer lengths apply to the rubber covered hose grades (RC, SI, FP).

Corroflon Mini-Sanitary and Sanitary Triclover Fittings - Not PTFE Lined



End Fitting Specification

- BS4825 Pt 3 (UK)
- ASME BPE-a-2007 (USA)
- DIN32676 (Europe, DN Sizes)
- ISO 1127 (Europe) (Non Standard, Specials Only)

Temperature and Pressure Ratings

For Standard Clamp and Standard (EPDM) Gasket

- Pressures up to 16 Bar (230 psi)
- Temperatures up to 120°C (250°F)
- Higher Pressures and Temperatures with Special Clamps and Gaskets.

End Fitting Materials

- Fittings in AISI 316L = EN 1.4404 = BS 316 S11. Internal Bores all Electropolished to <math>< 15\mu\text{in Ra}</math> (<math>< 0.375\mu\text{mtr}</math>).
- Ferrules, most in Grade 304 SS, some sizes in Grade 316L SS

Outlet Diameters (Inch pipe sizes only)

The outlet diameters as listed are in accordance with BS4825. The ASME specification, however, requires these diameters to be 0.005" (0.125mm) less in each case. An Outlet Diameter tolerance of +0.000 -0.005" has therefore been applied, so that the same fitting satisfies requirements of both specifications.

		MINI-SANITARY TRICLAMP (TRICLOVER) FITTINGS							
Nominal Hose Size	Nominal Pipe Size	*Fitting Length A		Flange Dia. D		Outlet Dia. I		Weight of Fitting	
		in	mm	in	mm	in	mm	Kg	Lbs
1/2"	1/2" & DN10	2.13	54	0.984	25.0	3/8	9.5	0.05	0.11
1/2"	3/4"	2.13	54	0.984	25.0	5/8	16.0	0.04	0.09
3/4"	3/4"	3.03	77	0.984	25.0	5/8	16.0	0.05	0.11

		SANITARY TRICLAMPS (TRICLOVER) FITTINGS							
Nominal Hose Size	Nominal Pipe Size	*Fitting Length A		Flange Dia. D		Outlet Dia. I		Weight of Fitting	
		in	mm	in	mm	in	mm	Kg	Lbs
1/2"	1"	2.01	51	1.984	50.5	7/8	22.2	0.13	0.28
3/4"	DN15	2.96	75	1.156	34.0	5/8	16.0	0.12	0.26
3/4"	ISO (DN) 15	2.96	75	1.984	50.5	0.713	18.10	0.16	0.35
3/4"	ISO (DN) 20	2.96	75	1.984	50.5	0.934	23.7	0.15	0.33
1"	1"	3.39	86	1.984	50.5	7/8	22.2	0.25	0.54
1"	DN25	3.39	86	1.984	50.5	1	26.0	0.24	0.52
1"	ISO (DN) 25	3.39	86	1.984	50.5	1.170	29.7	0.23	0.52
1"	1 1/2"	3.39	86	1.984	50.5	1 3/8"	34.9	0.22	0.48
1 1/2"	1 1/2"	4.02	102	1.984	50.5	1 3/8"	34.9	0.27	0.59
1 1/2"	DN40	4.02	102	1.984	50.5	1 1/2"	38.0	0.25	0.56
2"	2"	4.25	108	2.516	64.0	1 7/8"	47.6	0.39	0.86
2"	DN50	4.25	108	2.516	64.0	1.975	50.0	0.37	0.82
2"	2 1/2"	4.13	105	3.047	77.5	2 3/8"	60.3	0.42	0.92
2"	DN65	4.13	105	3.047	77.5	2.600	66.0	0.40	0.88
2"	3"	4.53	115	3.579	91.0	2 7/8"	73.0	0.68	1.50
2"	DN80	4.53	115	4.176	106.0	3.191	81.0	1.12	2.47

*Fitting Lengths listed are for Corroflon braided only hose grades (SS, PB, HB, KYB). Approximately 33% longer lengths apply to the rubber covered hose grades (RC, SI, FP).

Corroflon 90° Elbow Triclover Fittings (90° Elbow Mini-Sanitary & Sanitary Triclamp Fittings)



End Fitting Specification

- BS4825 Pt 3
- ASME-BPE-a-2007
- Others to Special Order

Temperature and Pressure Ratings

For Standard Clamp and Standard (EPDM) Gasket

- Pressures up to 16 Bar (230 psi)
- Temperatures up to 120°C (250°F)
- Higher Pressures and Temperatures with Special Clamps and Gaskets.

End Fitting Materials

- Fittings in Grade AISI 316L = EN 1.4404 = BS 316 S11
- Internal Bore average 15µin Ra, Electropolished if required
- Ferrules, most in Grade 304 SS, some sizes in Grade 316L SS

Outlet Diameters

The outlet diameters as listed are in accordance with BS4825. The ASME specification, however, requires these diameters to be 0.005" (0.125mm) less in each case. An Outlet Diameter tolerance of +0.000 -0.005" has therefore been applied, so that the same fitting satisfies requirements of both specifications.

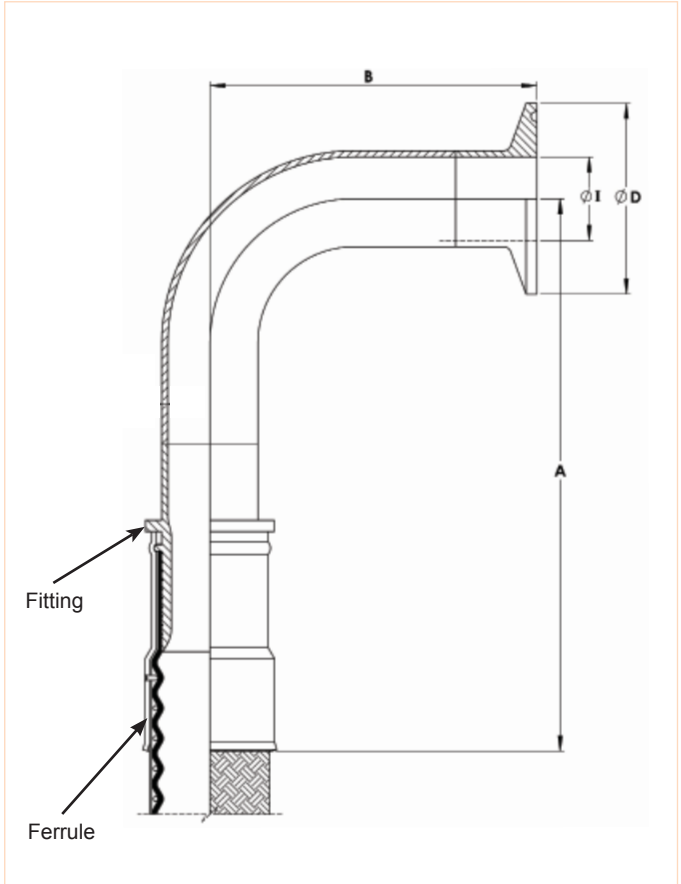

Nominal Hose Size		*Centre Line To Fitting End A		Centre Line to Face B		Flange Diameter D		*Outlet Diameter I		Weight of Fitting	
in	mm	in	mm	mm	mm	in	mm	in	mm	Kg	Lbs
1/2	13	5.78	147	1.60	41.0	0.984	25.0	3/8	9.5	0.137	0.30
3/4	20	6.41	163	1.60	41.0	0.984	25.0	5/8	16.0	0.205	0.45
1	25	6.53	166	2.00	51.0	1.984	50.5	7/8	22.2	0.347	0.77
1 1/2	40	7.99	203	2.75	70.0	1.984	50.5	1 3/8	34.9	0.590	1.30
2	50	9.33	237	3.50	88.9	2.519	64.0	1 7/8	47.6	0.928	2.05

*Fitting Lengths listed are for Corroflon braided only hose grades (SS, PB, HB, KYB). Approximately 33% longer lengths apply to the rubber covered hose grades (RC, SI, FP).

Corroflon DIN 11851 Fittings

PTFE Lined and Non-Lined

DIN11851 FITTINGS (MALE & FEMALE), PTFE LINED

Description

DIN 11851 male and female fittings, integrally PTFE lined.

Also available non-lined, up to 4" (100mm), to special order.

Specification

Generally to German DIN 11851 specification.

NB: The PTFE lined male fitting is designed to be used without a rubber seal. Please note that when connecting to a PTFE Lined DIN11851 Male, extra spanner tightening of the nut is sometimes required in order to provide a leak free connection.

End Fitting Materials

- Spigots in Grade 316L SS
- Nuts in Grade 304 SS
- Ferrules, most in Grade 304 SS, some sizes in Grade 316L SS

Temperature & Pressure Ratings

- Sizes up to 1 1/2" MWP = 40 Bar (580 psi) up to 130°C (266°F)
- Sizes 2" & 3" MWP = 25 Bar (360 psi) up to 130°C (266°F)

Except where the applicable hose pressure/temperature ratings are lower (page 8).

90° Elbows - PTFE Lined 90° elbow fittings are available for some sizes and grades - see page 29.



DIN11851 Female Fitting



DIN11851 Male Fitting

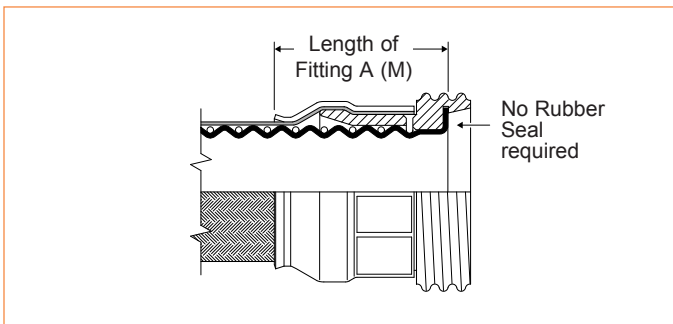
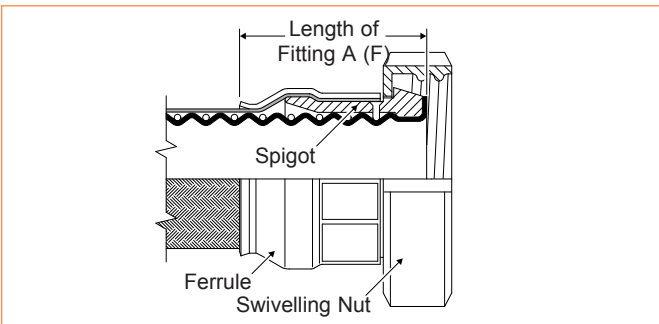

Nominal Hose Size		*Fitting Length (Male) A (M)		*Fitting Length (Female) A (F)		Weight of Fitting			
						Male		Female	
in	mm	in	mm	in	mm	Kg	Lbs	Kg	Lbs
3/4	20	2 3/8	60	2 3/8	60	0.18	0.39	0.22	0.48
1	25	2 3/8	60	2 5/8	67	0.22	0.48	0.36	0.79
1 1/4	32	2 1/2	65	2 3/4	70	0.27	0.59	0.47	1.04
1 1/2	40	2 5/8	67	2 7/8	73	0.33	0.73	0.55	1.21
2	50	2 5/8	67	2 7/8	73	0.58	1.28	0.93	2.05
2 1/2	65	3 1/2	89	3 5/8	92	0.73	1.61	1.31	2.88
3	80	4	100	3 5/8	92	1.00	2.20	1.57	3.46

*Fitting Lengths listed are for Corroflon braided only hose grades (SS, PB, HB, KYB). Approximately 33% longer lengths apply to the rubber covered hose grades (RC, SI, FP).

DIN11851 FEMALE FITTINGS, NOT PTFE LINED

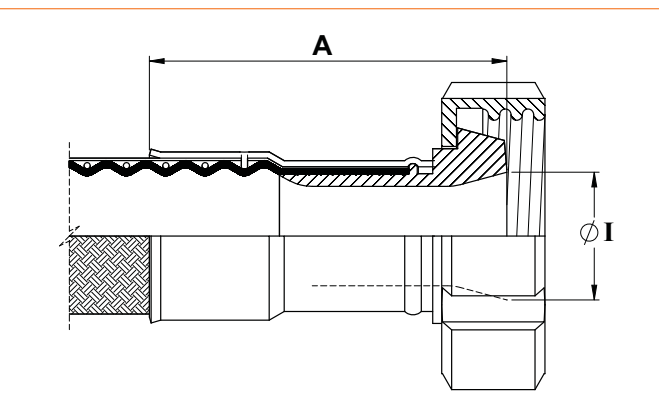

Description - DIN11851 Female Fittings, Non-Lined, are available in sizes 3/4", 1", 1 1/2", 2", 2 1/2", 3" and 4". Consult Aflex Hose for details.

Materials - Spigots in Grade 1.4571 (AISI 316 Ti), Nuts in Grade 304 SS, Ferrules, most in Grade 304 SS, some in Grade 316 SS.

Nominal Hose Size		ID (I)		Fitting Length (A)		Fitting Weight	
in	mm	in	mm	in	mm	Kg	Lbs
1/2	13	16	0.63	48	1.89	0.18	0.40
3/4	20	20	0.79	73	2.87	0.24	0.53
1	25	26	1.02	74	2.91	0.41	0.90
1 1/4	32	32	1.26	89	3.50	0.52	1.15
1 1/2	40	38	1.50	101	3.98	0.75	1.65
2	50	50	1.97	105	4.13	1.11	2.45

Corroflon SMS Female Fittings - PTFE Lined, RJT Female Fittings - Non Lined

End Fitting Specification

- SMS generally to Swedish SMS1148 specification.
- RJT generally to British BS4825 Pt 5 specification.

Temperature and Pressure Ratings

- Pressures up to 10 Bar (150 psi)
- Temperatures up to 150°C (302°F)

End Fitting Materials

- Spigots in Grade 316L SS
- Nuts in Grade 304 SS
- Ferrules, most in Grade 304 SS, some sizes in Grade 316L SS

90° Elbows

- PTFE Lined 90° elbow fittings are available for some sizes and grades
- see page 29.

SMS FEMALE FITTINGS

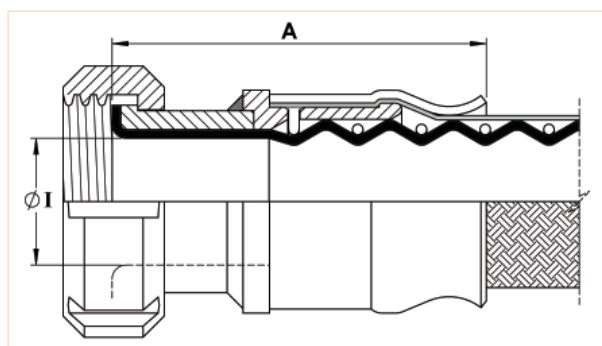

Nominal Size		*Length A		Outlet Dia. I		Weight of Fitting	
in	mm	in	mm	in	mm	Kg	Lbs
1	25	3/8	79	1	25	0.60	1.32
1 1/2	40	3 1/2	89	1 1/2	38	0.98	2.16
2	50	3 3/4	95	2	50	1.22	2.69
2 1/2	65	4 5/8	116	2 1/2	63	1.549	3.41
3	80	4 3/4	122	3	75	1.997	4.40

RJT FEMALE FITTINGS

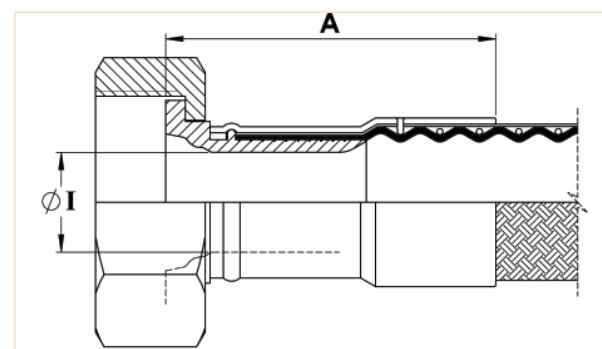

Nominal Size		*Length A		Outlet Dia. I		Weight of Fitting	
in	mm	in	mm	in	mm	Kg	Lbs
1	25	2.68	68	0.80	20.24	0.27	0.6
1 1/2	40	3.78	96	1.25	31.75	0.49	1.08
2	50	3.90	99	1.75	44.45	0.67	1.48
2 1/2	65	4.09	104	2.25	57.15	0.78	1.72
3	80	4.21	107	2.63	66.7	0.89	1.96

*Fitting Lengths listed are for Corroflon braided only hose grades (SS, PB, HB, KYB). Approximately 33% longer lengths apply to the rubber covered hose grades (RC, SI, FP).

Corroflon NPT and BSPT Fixed Male and NPT Fixed Female Fittings

End Fitting Specification

- NPT Taper Threads to American National Standard Pipe Taper Thread design to ANSI/AMSE B1.20.1
- BSPT Threads to British Standard Pipe Taper Thread design to BS21
- Alternatives - Parallel Threads, Metric Threads and Others.

End Fitting Materials

- Fittings in Grade 316L SS
- Ferrules, most in Grade 304 SS, some sizes in Grade 316L SS
- Alternatives - Fittings in Zinc Plated Carbon Steel

FIXED MALE NPT or BSPT

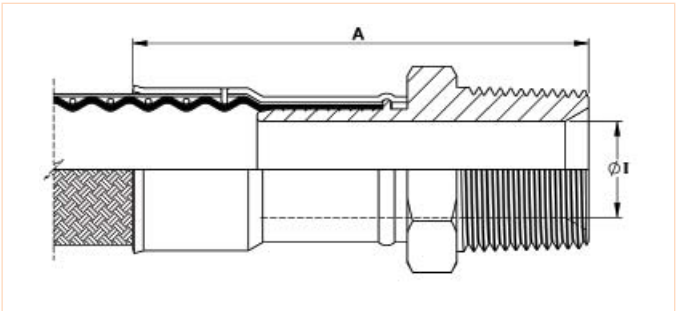

Nominal Hose Size		*Fitting Length A		Inside Diameter I		Weight of Fitting	
in	mm	in	mm	in	mm	Kg	Lbs
1/2	15	2 ⁵ / ₈	67	0.38	9.53	0.10	0.22
3/4	20	3 ¹ / ₂	89	0.63	15.88	0.18	0.40
1	25	3 ⁷ / ₈	98	0.80	20.24	0.29	0.64
1 ¹ / ₄	32	4 ³ / ₈	110	1.03	26.21	0.45	0.99
1 ¹ / ₂	40	5 ¹ / ₈	130	1.25	31.75	0.60	1.32
2	50	5 ¹ / ₂	140	1.75	44.45	0.84	1.85
2 ¹ / ₂	65	6 ³ / ₄	170	2.25	57.15	1.70	3.75
3	80	6 ³ / ₄	170	2.63	66.70	2.53	5.58
4	100	7 ¹ / ₂	190	3.50	88.90	3.99	8.80

*Fitting Lengths listed are for Corroflon braided only hose grades (SS, PB, HB, KYB). Approximately 33% longer lengths apply to the rubber covered hose grades (RC, SI, FP).

FIXED FEMALE NPT

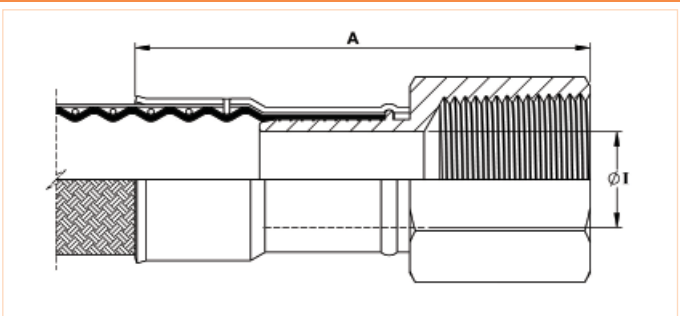

Nominal Hose Size		NPT or BSPT Thread Size	*Fitting Length A		Fitting Inside Diameter I		Weight of Fitting	
in	mm	in	in	mm	in	mm	Kg	Lbs
1/2	13	1/2	2.72	69	0.38	9.53	0.18	0.40
3/4	20	3/4	3.54	90	0.63	15.88	0.22	0.49
1	25	1	3.82	97	0.80	20.24	0.33	0.73
1 ¹ / ₂	40	1 ¹ / ₂	4.96	126	1.25	31.75	0.75	1.65
2	50	2	5.16	131	1.75	44.45	1.06	2.34

*Fitting Lengths listed are for Corroflon braided only hose grades (SS, PB, HB, KYB). Approximately 33% longer lengths apply to the rubber covered hose grades (RC, SI, FP).

Corroflon BSP 60° Cone Seat Female Unions and BSP Flat Seat Lug Nut Female Fittings

End Fitting Specification

- BSPP Threads to British Standard Pipe Parallel Thread design to BS21, 60° Cone Seat design, or Flat Seat.

Alternatives - Cone Seat Female Union Fittings can be supplied with a BSPP/BSPT Taper Male Adaptor if required.

Available in sizes up to 4"

End Fitting Materials

- Spigots in Grade 316L SS
- Nuts in Grade 316L SS
- Ferrules, most in Grade 304 SS, some sizes in Grade 316L SS

Alternatives

- Cone Seat Female Unions can be supplied in Zinc Plated Carbon Steel if required.
- Lug Nuts can be supplied in Gun Metal (Bronze) if required.

BSP 60° CONE SEAT FEMALE UNION FITTING

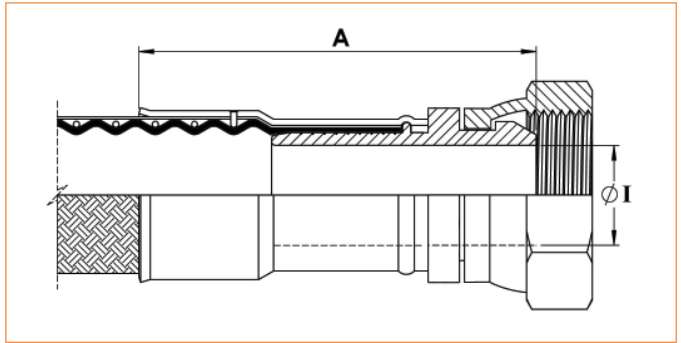

Nominal Hose Size		NPT or BSPT Thread Size	*Fitting Length A		Fitting Inside Diameter I		Weight of Fitting	
in	mm		in	mm	in	mm	Kg	Lbs
1/2	13	1/2	2 1/2	63	0.37	9.35	0.11	0.25
3/4	20	3/4	3 1/2	89	0.63	15.88	0.15	0.34
1	25	1	3 1/2	89	0.80	20.24	0.24	0.53
1 1/2	40	1 1/2	3 7/8	98	1.25	31.75	0.72	1.59
2	50	2	4	100	1.75	44.45	0.99	2.19

BSP FLAT FACE LUG NUT FEMALE FITTING

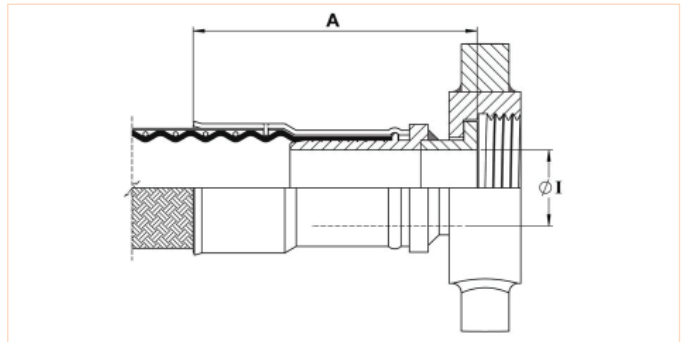

Nominal Hose Size		BSPP Thread Size	*Fitting Length A		Fitting Bore Diameter I		Weight of Fitting	
in	mm		in	mm	in	mm	Kg	Lbs
1	25	1	2.72	69	0.80	20.24	0.25	0.55
1 1/2	40	1 1/2	3.78	96	1.25	31.75	0.61	1.33
2	50	2	3.90	99	1.75	44.45	0.88	1.95

*Fitting Lengths listed are for Corroflon braided only hose grades (SS, PB, HB, KYB). Approximately 33% longer lengths apply to the rubber covered hose grades (RC, SI, FP).

Corroflon 37° JIC Female Fittings and NPT Male or Female Unions

End Fitting Specification

- SAE J514 37° Flare JIC Female Fitting
- 37° JIC Male-to-NPT Male/Female Adaptors
- NPT Threads to ANSI B2.1

Temperature and Pressure Ratings

Same Maximum Working Pressure and Temperature as for the relevant size of Corroflon Hose, on page 7.

End Fitting Materials

- Spigots in Grade 316L SS
- Nuts in 316L SS
- Ferrules, most in Grade 304 SS, some sizes in Grade 316L SS

Note - Not usable with SAE 45° Flare fittings which have the same thread..

Alternatives - Can be supplied in other materials, such as zinc plated carbon steel, Hastelloy, Monel etc.

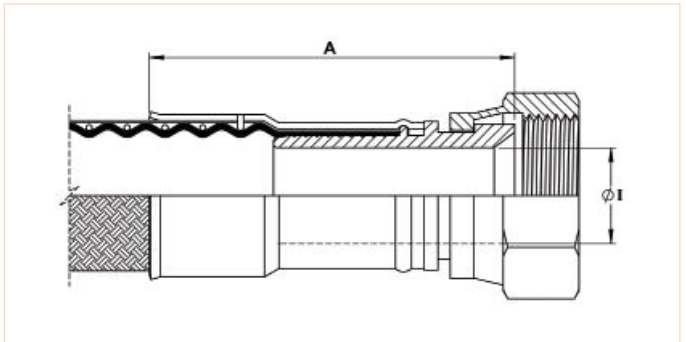

Nominal Hose Size		37° JIC Thread Size	*Fitting Length A		Hex Size H		Fitting Inner Diameter I		Weight of Fitting	
in	mm	in	in	mm	in	mm	in	mm	Kg	Lbs
1/2	13	3/4 -16	2.13	54	0.88	22.2	0.38	9.5	0.11	0.24
3/4	20	11/16 -12	2.99	76	1.25	31.7	0.63	15.9	0.15	0.34
1	25	15/16 -12	3.66	93	1.50	38.1	0.80	20.2	0.23	0.52
1 1/2	40	17/8 -12	4.17	106	2.25	57.1	1.25	31.7	0.72	1.58
2	50	2 1/2 -12	4.49	114	2.88	73.0	1.75	44.4	0.99	2.18

*Fitting Lengths listed are for Corroflon braided only hose grades (SS, PB, HB, KYB). Approximately 33% longer lengths apply to the rubber covered hose grades (RC, SI, FP).

JIC TO NPT MALE UNION (Including a JIC MALE-TO-NPT MALE ADAPTOR)

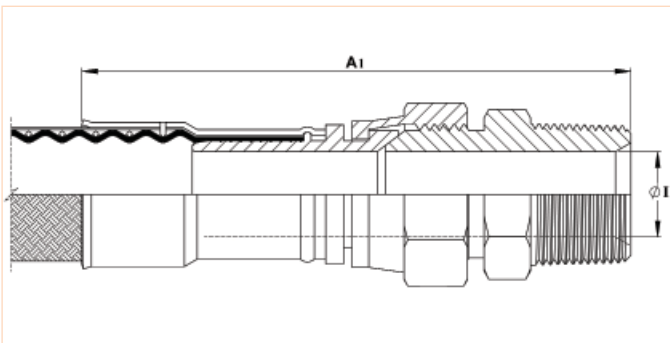

JIC TO NPT FEMALE UNION (Including a JIC MALE-TO-NPT FEMALE ADAPTOR)

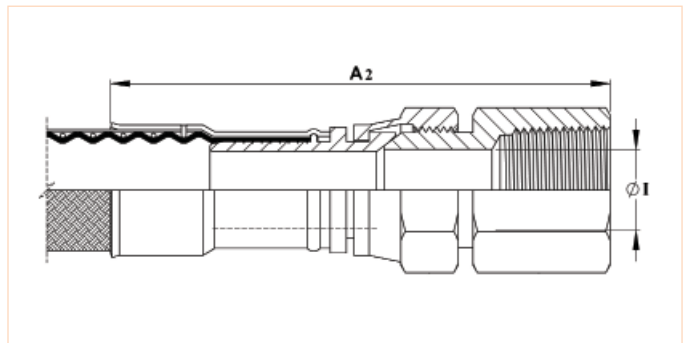

Nominal Hose Size		*Male Union Length A1		Weight of Fitting	
in	mm	in	mm	Kg	Lbs
1/2	13	4.13	105	0.22	0.48
3/4	20	4.92	125	0.33	0.72
1	25	5.43	138	0.52	1.15

*Female Union Length A2		Fitting Inner Diameter I		Weight of Fitting	
in	mm	in	mm	Kg	Lbs
3.62	92	0.38	9.5	0.21	0.47
4.80	122	0.63	15.9	0.33	0.74
5.35	136	0.80	20.2	0.68	1.50

*Fitting Lengths listed are for Corroflon braided only hose grades (SS, PB, HB, KYB). Approximately 33% longer lengths apply to the rubber covered hose grades (RC, SI, FP).

Corroflon PTFE Dip Pipes, Straight or 90° Elbow

FIXED DIP PIPES

Description

Fixed Dip Pipes are fairly rigid, thick wall PTFE tubes, either straight or 90° elbowed, which are directly crimped to the end of Corroflon hoses. They are designed for insertion into drums, tanks and reaction vessels in order to suction drain (or inject) process fluids transferred through the hose.

Materials

- Standard dip pipes are in anti-static (AS) PTFE
- Ferrules, most in Grade 304 SS, some sizes in Grade 316L SS

How to order

Specify the size and material of the dip pipe, whether it is straight or 90° elbowed. Give the length of the straight leg of the dip pipe and the length of the rest of the hose assembly separately.

Maximum Working Pressures

Dip Pipes are normally only tested to 4 Bar Pressure, and are not suitable for use at pressures higher than 3 Bar. They are usable at negative pressure up to full vacuum.

If higher pressure ratings are required, consult Aflex Hose.

Lengths

Dip Pipes are supplied as standard in 1 metre straight lengths, but can be supplied in any length to individual requirements.



Nominal Hose Bore Size		Approximate Dip Pipe Dimensions			
		Outside Diameter D		Inside Diameter I	
in	mm	in	mm	in	mm
3/4	20	0.87	22	0.51	13
1	25	1.14	29	0.83	21
1 1/2	40	1.54	39	1.00	27
2	50	2.17	55	1.58	40

FIXED DIP PIPE (STRAIGHT)

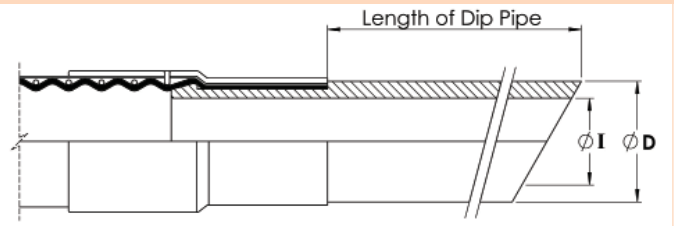

DETACHABLE DIP PIPES

Description

As Fixed Dip Pipes above, but connected to the hose through an end fitting, not by crimping direct to the hose.

Design

A straight, or 90° elbowed anti-static PTFE Dip Pipe, fitted with a Flange or Cam & Groove Male PTFE Lined & Flared end fitting.

The most usual end fitting is a Cam Male (as shown), so the dip pipe can then be connected to a hose with a Cam Female end fitting.

Specifications

As above for Fixed Dip Pipes.

DETACHABLE DIP PIPE

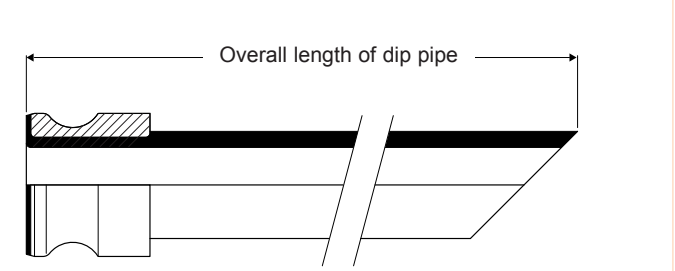

Corroflon 90° Elbow Fittings, PTFE Lined and Non-Lined

PTFE LINED 90° ELBOW FITTINGS

Scope - All of the PTFE lined end fittings described on previous pages can be fitted as 90° elbow PTFE lined fittings to the design shown, to the sizes listed.

- All grades of hose can be used, except PB and KYB.

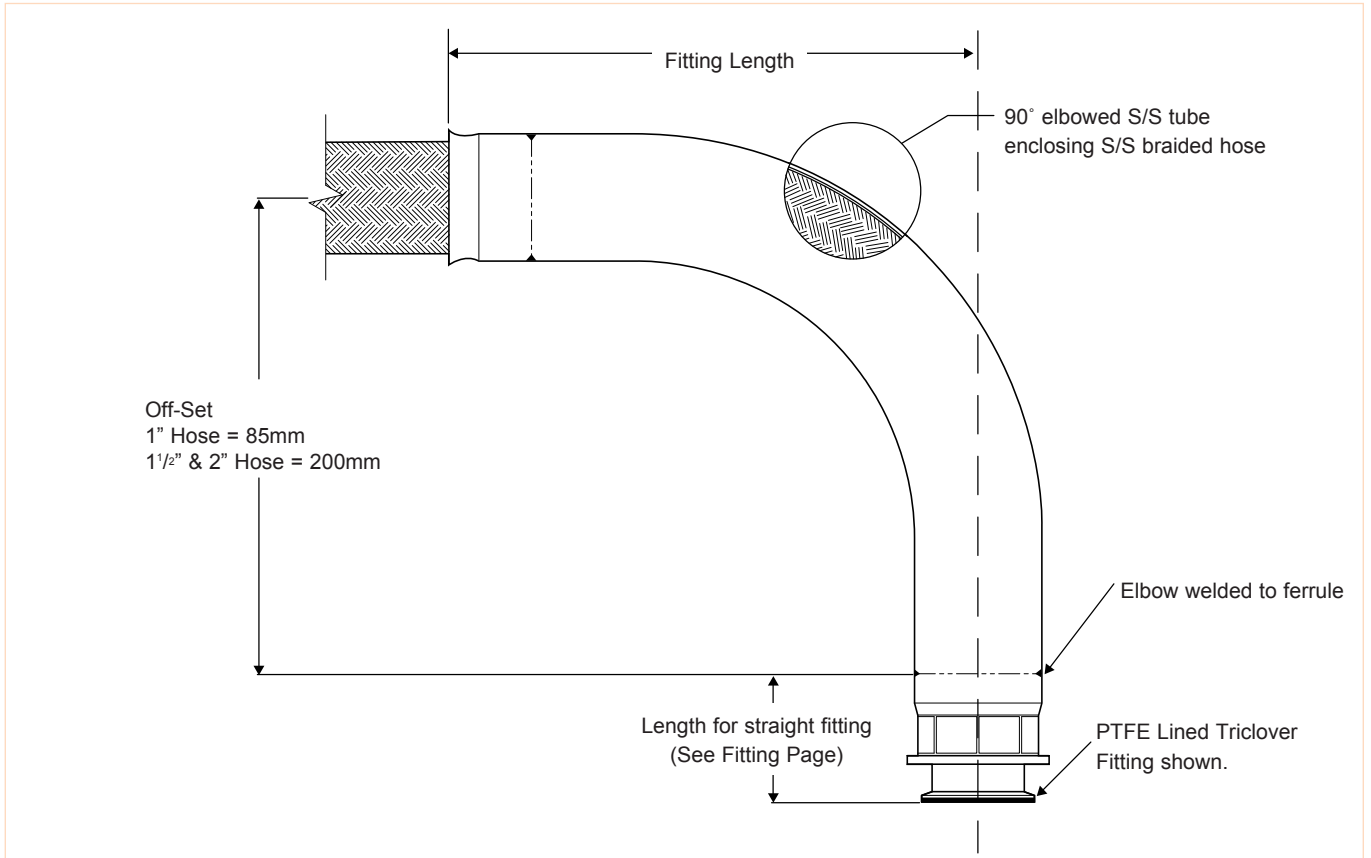

Hose Bore Sizes	Off-Set	Fitting Length	Weight of Fitting	
			Kg	Lbs
1"	85	143	0.48	1.07
1 1/2"	200	237	1.37	3.03
2"	200	314	1.68	3.70

NON-LINED 90° ELBOW END FITTINGS

A 90° elbow attached to the hose can be supplied non-PTFE lined, as shown, for any size or grade of hose or type of fittings, to special order.

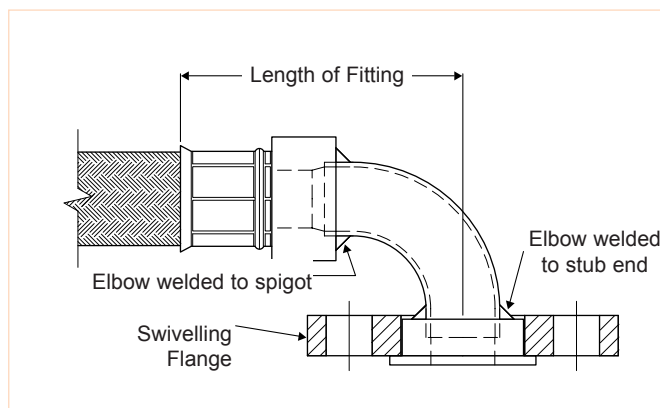

Corroflon Steam Heated Hose Assemblies. (CH Grade)

CH Hose Assembly

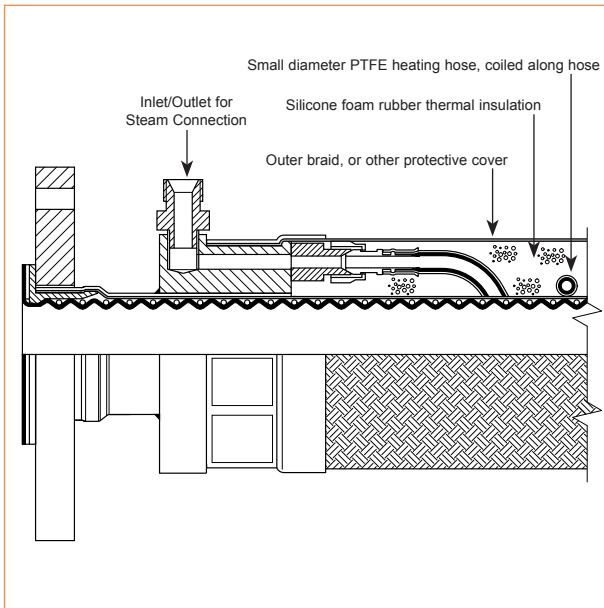

Purpose

For use in applications where the temperature of the process fluid entering the hose assembly must be maintained as it passes through the hose. This is usually required to prevent solidification or an increase in the fluid viscosity. Steam or hot oil heating is preferred to electrical heating in some applications for reasons of availability or safety, but is less controllable.

Description

The heating element comprises a small diameter PTFE heating hose, 6mm or 9.5mm bore size, with a single SS wire braid. This is spirally wrapped around the hose, with inlet and outlet ports attached either both at one end or at opposite ends of the hose assembly. In the case of hose assemblies longer than 3 metres, it is usual to have not one but several heating hoses with inlet ports at opposite ends and along the hose. This reduces the effects of temperature loss over the length of the hose assembly. The thermal insulation is closed-cell, fire resistant silicone foam rubber. The outer cover may be SS wire braid with or without a rubber cover if necessary.

Design

Each hose is custom designed and built to suit the requirements of the particular application. The following information is therefore required:

Fluid in Hose Assembly

Maintained Temperature of Fluid in Hose

Temperature of Steam or Fluid in the Heating Hose

Min/Max Ambient Temperature

External Conditions of Abrasion etc

Specifications

As for Corroflon GP, SS on page 7, except the size range is 1" to 3", the minimum bend radius is tripled, and the outside diameter and weight are significantly increased in line with the particular design.

Limitations

1" PTFE lined PN10 flange spigots on heated hoses can only have a maximum flare diameter of 50mm, not 63mm.

If the hose is "hanging", straight or at 90°, under its own weight, special construction is required, so advise Aflex Hose accordingly.

Minimum CH Hose Assembly Length 750mm.

Not recommended for use with PB braid.

Corroflon Electrically Trace Heated Hose Assemblies. (ETH Grade)

Purpose

For use in applications where the temperature of the process fluid entering the hose assembly must be regulated as it passes through the hose. This is usually required to prevent solidification or an increase in the fluid viscosity. In some applications, an additional 'heating up' or 'melting' facility is also required. Electrical heating is often preferred to steam heating because it is more convenient, more controllable and usually more readily available. 'Zone 1 Hazardous Area' requirements can be met.

Description

The heating element comprises either a resistance element or a self-regulating element spirally wrapped around the hose assembly. Self regulating elements may require a sensor and controller if a specific maintain temperature is required. Please consult Aflex Hose for clarification. Resistance element heated hoses usually also require a temperature sensor to be built in to the construction and must be used in conjunction with a temperature controller. The power leads and (if applicable) temperature sensor leads emerge from the hose assembly at one end, through glands and conduits. The thermal insulation is foam rubber, closed-cell fire resistant silicone foam rubber for temperatures above 80°C. The outer cover may be a Polypropylene Braid or SS wire braid with a rubber cover if necessary.

Design

Each hose is custom designed and built to suit the requirements of the particular application. Application details must be supplied by filling in an "ETH Hose Questionnaire", available from Aflex Hose. Generally, for Hazardous Areas, the Self Regulating type of heating element is employed, with or without a temperature sensor and control, and flameproof glands and conduit are also required. The watts per metre of the heating element, the pitch of the spiral on the hose, and the thickness of the thermal insulation are all calculated in accordance with established formulae to give the required maintained temperature for the process fluid passing through.

Specifications

As for Corroflon GP, SS on page 7, except that the minimum bend radius is tripled and the outside diameter and weight are significantly increased in line with the particular design. Maximum ETH Hose Assembly Lengths are as given for Corroflon GP, SS.

Limitations

1" PTFE lined PN10 flange spigots on heated hoses can only have a maximum flare diameter of 50mm, not 63mm.

If the hose is "hanging", straight or at 90°, under its own weight, special construction is required, so advise Aflex Hose accordingly.

Minimum ETH Hose Assembly Length, when collars are used 750mm.

ETH Hose Assembly

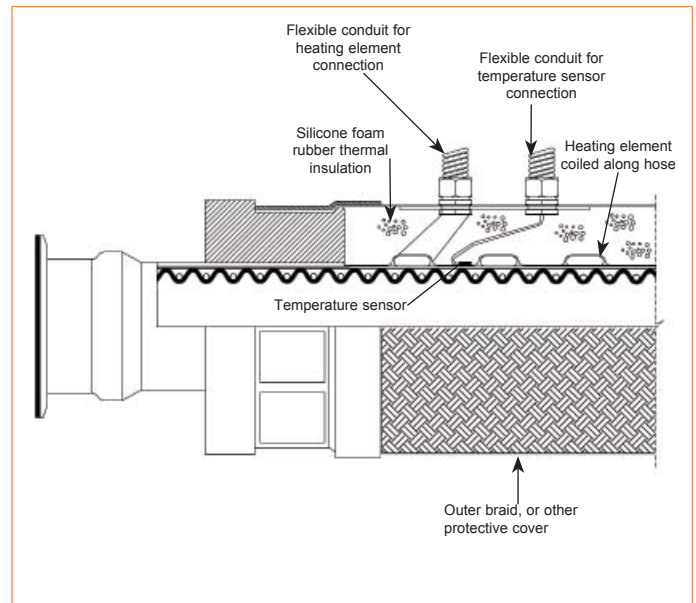

Corroflon Standard and Puretag Labelling and Colour Coding Systems

Standard Labelling

All Corroflon hose assemblies are labelled with the following information:

- Manufacturer's Name
- Hose Size and Grade
- Max. Working Pressure
- Unique Serial Number
- Month & Year of Manufacture
- Telephone Number
- CE Mark (if applicable)

This information is normally laser-etched on to a loose stainless steel Ring mounted on the hose.

In some cases, at the discretion of Aflex Hose, the information may be etched on to a thin stainless steel plate which is clamped to the hose, or on to the end fitting ferrule at one end. This may be necessary for example, if the customer requires additional information which may not fit on to a Ring.

Customers may specify which labelling system they require, and may request additional information on the label.



Puretag Labelling and Colour Coding

This system is only applicable to the EPDM (RC or FP) or Silicone (SI) rubber covered grades of Corroflon.

A label and/or Colour Code is encapsulated on to the braid by a transparent rubber cover which is integrally vulcanised and fully bonded to the rubber cover on the hose.

Another alternative is an RFID programmable tag, encapsulated in the Rubber (Aflex Hose "Flowtag" system) - consult Aflex Hose for details.

Further information is available on the Puretag product information document on the website.

Note: 1/2" size, Colour Code only, no text.



Colour Coding

This system is applicable to all grades of Corroflon hose.

A coloured PTFE spiral strip is wound on to the hose.

It can be left loose, or it can be encapsulated under a transparent, heat-shrunk polyolefin sleeve.



Correct Hose Configuration & Length Calculations - for Bend Radius

Hose Configuration Requirements

Hose Assemblies are usually connected at both ends in service. They may then either remain in a fixed, or static configuration or in a flexing, or dynamic configuration.

Whether static or dynamic, the First Rule concerning the configuration of the hose is that **the bend radius of the hose must never be less than the Minimum Bend Radius (MBR) for the hose** as listed in the relevant hose brochure.

The most common situation when this is likely to occur is when the hose is flexed at the end fitting, with stress being applied to the hose at an angle to the axis of the end fitting. Typically, this happens either because the length of the hose is too short, or because the weight of the hose plus contents creates a stress at an angle to the end fitting.

The Second Rule, therefore, if possible, is to **design the configuration to ensure that any flexing in the hose takes place away from the end fittings.**

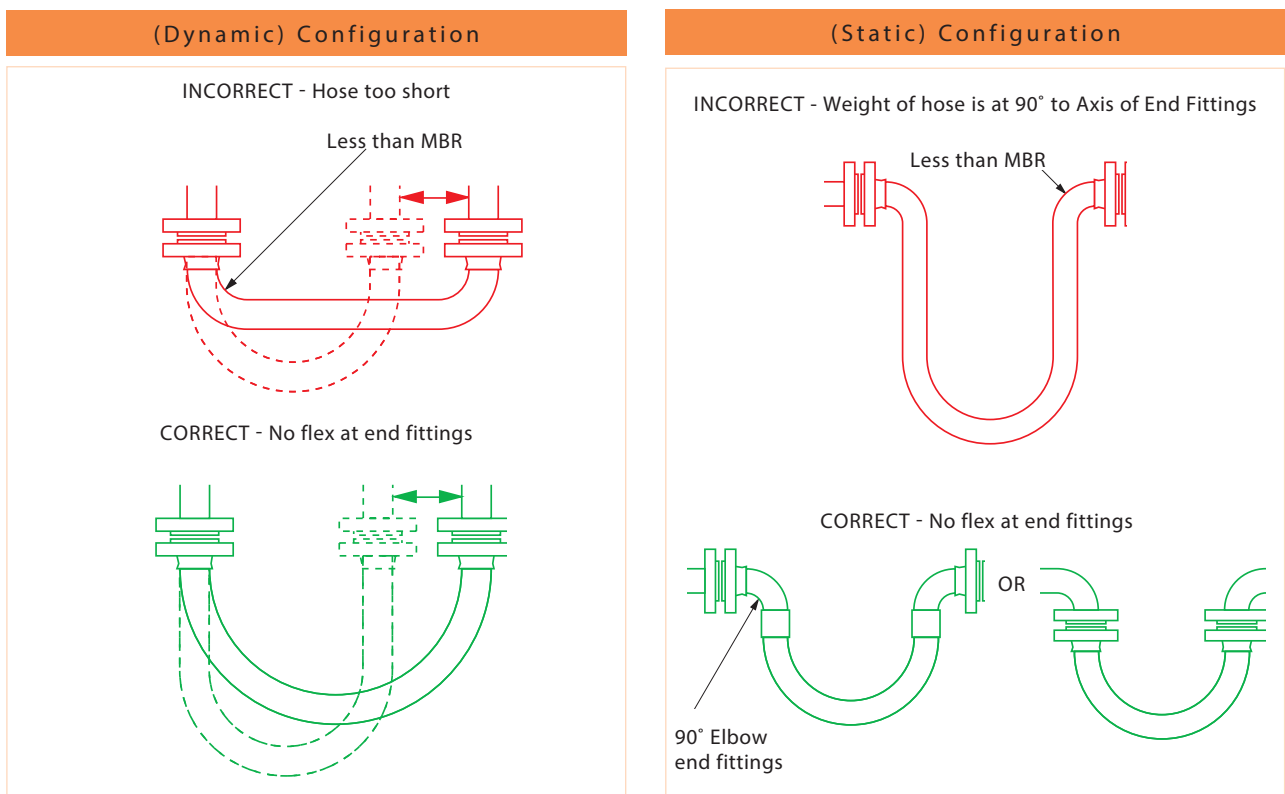

Correct Hose Configuration & Length Calculations - for Abrasion & Torque

The Third Rule is that the hose configuration should always be designed, and supported where necessary, to avoid any possibility of external abrasion.

In some cases, the length, configuration and angle of the hose can be designed to avoid abrasion. In others, static or moving support frames or support wheels are required.

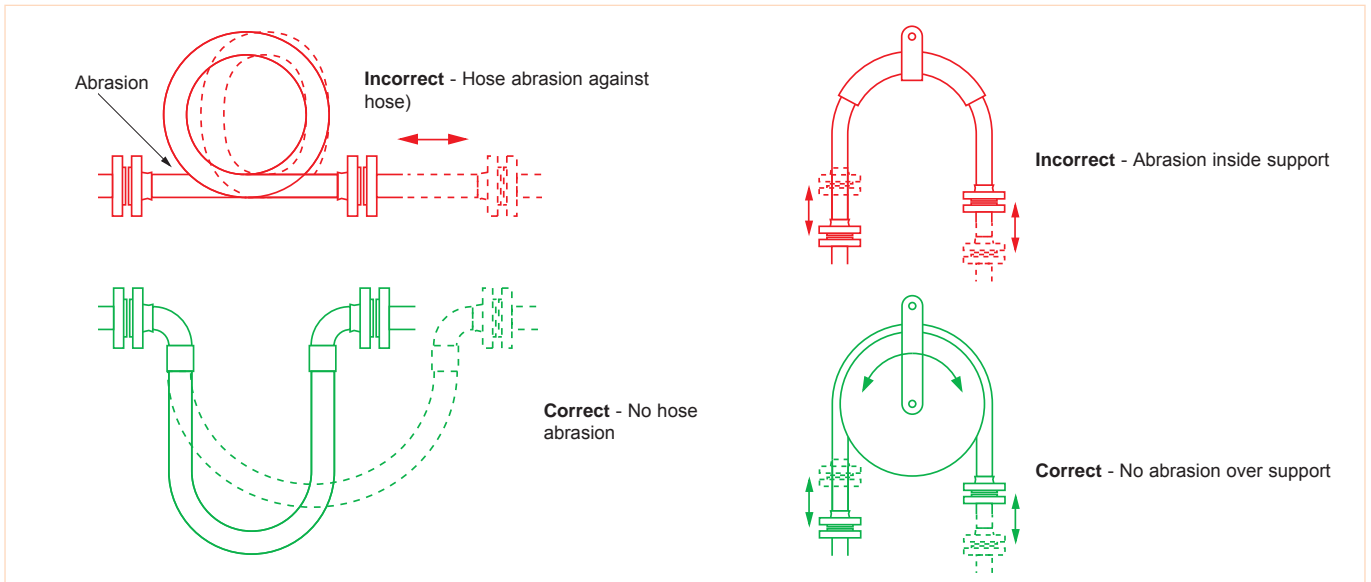

The Fourth Rule is that the hose must not be subjected to torque, either during connection, or as a result of the flexing cycle.

Torque (twist) in the hose can be applied during connection if the hose is accidentally twisted, or if the second end being connected is a screwed connection, and the hose is subjected to torque during final tightening.

In a flexing application, if any flexing cycle of the hose occurs in 3 dimensions instead of 2, then torque will also occur:

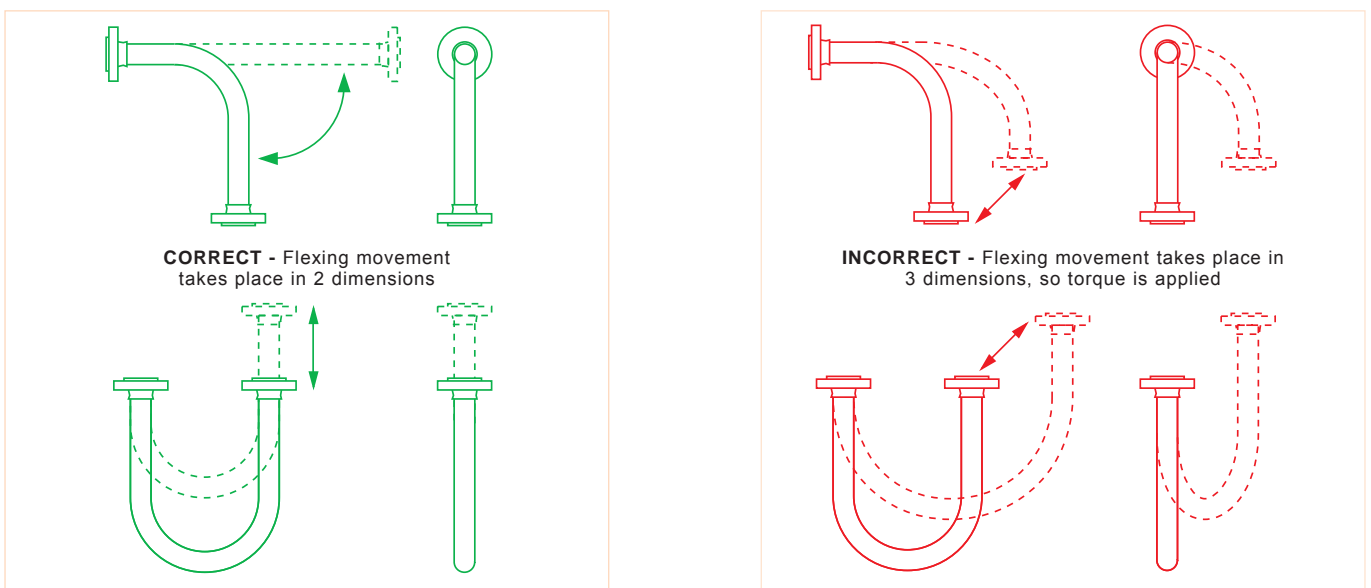

Both Corroflon and Bioflex hose have good resistance to a small level of torque, much better resistance than rubber or SS hose types, but it is still the best practice to take whatever steps are necessary to eliminate torque. If in doubt, consult Aflex Hose.

Hose Configurations & Length Calculations

- for Length Calculation

Calculating the Hose Length

The formula for calculating the bent section of the hose length around a radius is derived from the basic formula that the circumference of a circle = $2\pi R$, where R = the radius of the circle, and π = a constant, = 3.142.

So, if the hose goes around a 90° bend, which is $1/4$ of a full circumference, and the radius of the bend is R , then the length of the hose around the bend is = $1/4 \times 2\pi R$. Or half way round, in a U-shape, = $1/2 \times 2\pi R$.

Note :

In calculating the length of a hose assembly, the (non-flexible) length of the end fittings must be added in, also the length of any straight sections of hose, as in the following example:

Example :

To calculate the length for a 2" bore size hose with flange end fittings, to be fitted in a 90° configuration with one leg 400mm long, the other 600mm long.

$$\begin{aligned} \text{Length of Bent Section (yellow)} &= 1/4 \times 2\pi R \text{ (334)} \\ &= 1/4 \times 2 \times 3.142 \times 334 = \mathbf{525\text{mm}} \end{aligned}$$

$$\begin{aligned} \text{Length of top, Straight Section, including the top end fitting length} \\ &= 600 - 334 = \mathbf{266\text{mm}} \end{aligned}$$

$$\text{Length of bottom end fitting} = \mathbf{66\text{mm}}$$

$$\text{Total length of Hose Assembly} = 525 + 266 + 66 = \mathbf{857\text{mm}}$$

Things to consider

- A hose will normally take the longest radius available to it to go around a corner, not the MBR! Also - always remember to include the **non-flexible** end fitting lengths.
- In dynamic applications, remember to always calculate the lengths for the most extended configuration during the flexing cycle, not the least extended.
- If the configuration is simply too complex for calculation, then obtain a length of flexible tubing of some kind, mark on paper, or a wall, or floor, or both where the connection points will be relative to each other, scaled down if necessary, then manually run the flexible tubing between them with full radii round bends. Measure the extended length, then scale up if necessary to determine the approximate length of the hose.

If in doubt, consult Aflex Hose.

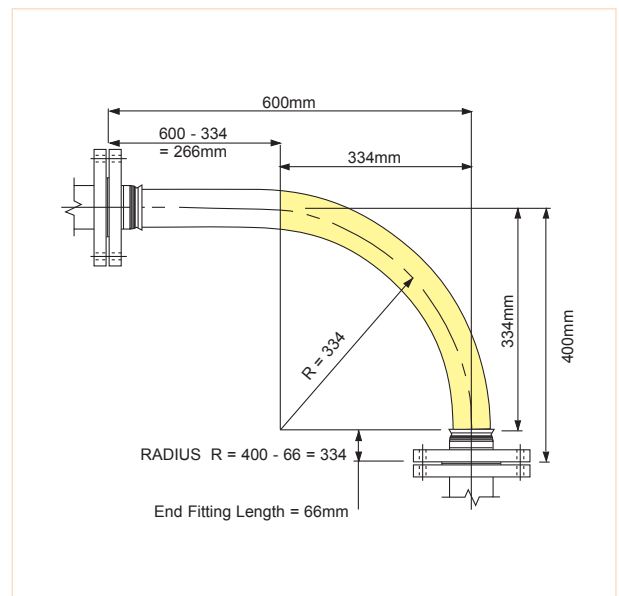
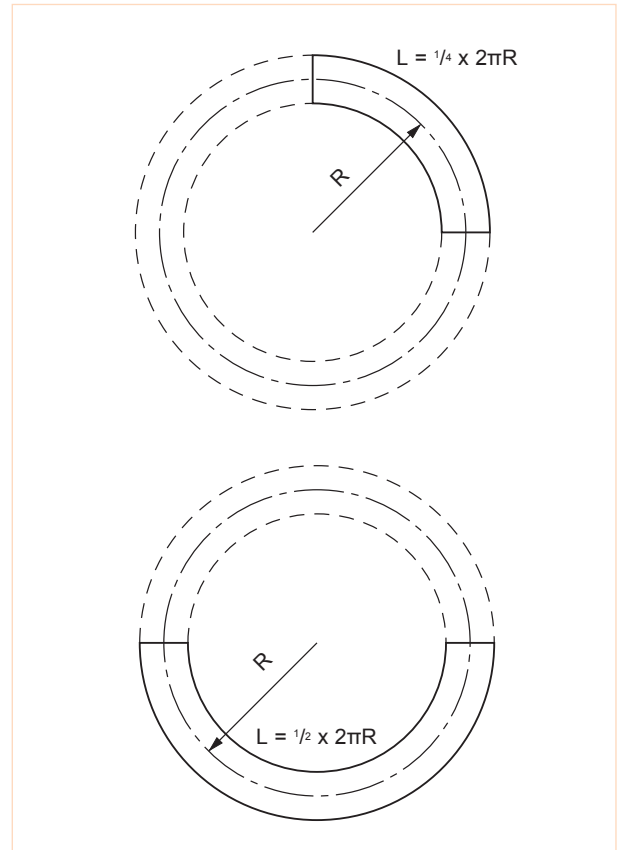

Conditions of Sale

Definitions

- (1) "Aflex Hose" shall mean Aflex Hose Limited
- (2) "Aflex Hose Products" shall mean those products the Customer is purchasing from Aflex Hose.
- (3) "Customer" shall mean the individual or entity that is purchasing Aflex Hose Products hereunder.
- (4) "Full Product Brochure" shall mean the brochure for each specific product available at <http://www.aflex-hose.com/products/>.

General

(5) These Conditions of Sale form the basis of the contract of sale between Aflex Hose and the Customer. In the event of any conflict between the terms and conditions set forth in these Conditions of Sale and any other Customer document, these Conditions of Sale shall govern, unless otherwise agreed to in writing and authorized and signed for by a Director or General Manager of Aflex Hose.

(6) Unless otherwise agreed to in writing, delivery will be at cost from Aflex Hose's facilities Brighouse, West Yorkshire, England. Title and all risks of loss or damage pass to the Customer upon delivery to the Customer or third party carrier. Delivery dates specified by Aflex Hose are only Aflex Hose's best estimates and Aflex Hose's only responsibility will be to use reasonable commercial efforts to meet all specified delivery dates.

Customer Responsibilities and Obligations

(7) It is the Customer's strict responsibility to review all of the usage conditions and usage limitations given for the Aflex Hose Products which are intended for use in a particular application, to ensure that the application conditions are in compliance with those usage limitations. The usage conditions and limitations are referred to in these Conditions of Sale, and are further specified in the relevant Full Product Brochure. The Customer shall consult the latest, up to date hose product information and Full Product Brochure at the time of ordering, which are only available and downloadable from the Aflex Hose website at <http://www.aflex-hose.com/products/>, or on request from Aflex Hose. The Customer here represents and warrants that it has read and understands the applicable Full Product Brochure and the usage conditions and the usage limitations set forth therein, and has ensured their compliance with the application conditions.

(8) If the Customer sells or assigns any Aflex Hose Products to any other person or entity, the Customer shall ensure that the final end user of the Aflex Hose Products is supplied with these Conditions to Sale, the applicable Full Product Brochures, the Aflex Hose website address, together with notification of the requirement to review the usage conditions and limitations. The Customer shall include the terms and conditions set forth herein in its Conditions of Sale to any third party. The Customer hereby agrees and acknowledges that Aflex Hose shall have no liability whatsoever for claims arising in whole or in part out of the Customer selling or assigning the Aflex Hose Products to a third party that does not use the Aflex Hose Products in accordance with Aflex Hose's usage requirements and limitations ("Non-Conforming Use Claims"). The Customer shall indemnify and hold harmless Aflex Hose, its officers, directors, employees, affiliates and representatives for any and all claims, damages, penalties and losses arising out of or related to Non-Conforming Use Claims.

(9) The Customer agrees and acknowledges that for any intended hose application in which special conditions apply which are not defined, or not defined sufficiently in the Product Brochure, the Customer shall write to Aflex Hose requesting written advice relating to any usage limitations resulting from special conditions. The Customer shall ensure the design suitability and safety of the Aflex Hose Products in their intended applications, giving particular consideration to any special condition relating to, but not restricted to the chemical and electrostatic compatibility of the fluids or gases passing through, the possibility of diffusion of fluid or gases through the PTFE hose lining, the possibility of external corrosive conditions, the types and likelihood of excessive mechanical abuse, such as abrasion (internal or external), crushing, excessive flexing or vibrations, etc. and any excessive temperature and/or pressure "pulsing" conditions, or any other condition which may cause premature hose failure. The Customer shall consider, and take account of the degree of risk involved in any hose failure, including the provision of adequate protection in the event of any risk to any persons. In applications where any type of hose

failure would lead to financial losses if the hose is not replaced immediately, the Customer agrees and acknowledges that it shall be the Customer's responsibility to order and hold in stock spare hose(s) accordingly. The Customer shall advise Aflex Hose in writing at the time of placing the enquiry and on any purchase order if there are any special requirements for the hose, including special cleaning, or drying, or extra testing requirements which are in addition to normal industrial standards. The Customer agrees and acknowledges that Aflex Hose, its officers, directors, employees, affiliates and representatives shall not be held liable for any claims or obligations arising out of the Customer's failure to fulfill any or all of its responsibilities set forth in this Section 9.

(10) If the Customer has any doubts concerning these or any other usage conditions and limitation or safety parameters, the Customer shall consult Aflex Hose at the number and address in the Notice Provisions below and request a written response to any queries.

Hose Service Life; 24 Month Warranty

(11) It is not possible to guarantee a minimum service life for any of the Aflex Hose Products which can be applicable for every type of application. As such, Customer acknowledges that, except as provided below in Sections 12, 13 and 14 Aflex Hose is not guaranteeing a minimum service life of any of the Aflex Hose Products.

(12) Service life predictions or guarantees can only be given in cases where all the relevant information concerning the application is given in writing to Aflex Hose, and Aflex Hose subsequently replies in writing with the service life prediction prior to the order being placed.

(13) If such a written undertaking is not sought and given, Aflex Hose shall not be held liable for any Aflex Hose Product failure which the Customer considers to be premature, excepting failures which are due to faulty materials or manufacturing defects which occur within 24 months or 12 months, as applicable, of supply as provided in Section 14 below.

(14) Aflex Hose warrants its Aflex Hose Products to be free from faulty materials or manufacturing defects from the date of the delivery, for 24 months; provided, however, that all Hose Assemblies which are "ETH" (Electrical Trace Heated) Grade are only warranted for 12 months.

(15) AFLEX HOSE MAKES NO WARRANTY OF ANY KIND WHATSOEVER, EXPRESS OR IMPLIED OTHER THAN AS SPECIFICALLY STATED HEREIN, AND THERE ARE NO WARRANTIES OF MERCHANTABILITY AND/OR FITNESS FOR A PARTICULAR PURPOSE WHICH EXCEED THE OBLIGATIONS AND WARRANTIES SPECIFICALLY STATED HEREIN.

Product Failure

(16) In the event of a product failure during the applicable warranty period set forth in Section 14, the Customer shall provide Aflex Hose with written notification within forty-eight (48) hours of discovering the fault. Aflex Hose requires that the Aflex Hose Products not be cut up or tampered with, but should be decontaminated and returned to Aflex Hose, plus a decontamination certificate, for examination and analysis of the fault. The Customer should also provide full details in writing of the application conditions under which the hose failed, including Pressure, Vacuum, Temperature, Flexing and any cycling of any of these, also the fluids, gases and any cleaning products passed through the hose, and the total time that the hose has been in service also the original order number and the Serial Number for the hose. The Customer may send its own witness to the examination if required. Aflex Hose will provide a Non-Conformance Report to the Customer. The Customer shall bear the cost of returning the Aflex Hose Products that have failed; provided, however, as set forth in Section 17 below, Aflex Hose shall reimburse the Customer for any shipping costs if it is determined that the failure is covered by the warranty set forth in Section 14.

Conditions of Sale Continued

(17) If Aflex Hose determines that the faulty materials or a manufacturing defect in the hose is responsible for the hose failure, Aflex Hose's maximum liability shall be the invoice value of the failed hose itself, or the invoice value of the whole customer order as determined by Aflex Hose in its sole discretion, along with any reasonable costs for removal and replacement of the hose, and costs for packing and despatching the failed hose back to Aflex Hose.

Untested Hose for Self Assembly by Customers

(18) Aflex Hose sometimes supplies "loose" hose, without end fittings attached to a Self Assembly Customer, who will then cut the hose to length and attach end fittings to make up Hose Assemblies for their own use, or for sale to their own customers.

(19) Unless the Customer requests, and Aflex Hose confirms that the 'loose' hose is pressure tested before supply, such testing is not normally applied by Aflex Hose, because this testing requirement is otherwise satisfied by the Self Assembly Customer during his own testing of the finished Hose Assemblies made up using the "loose" hose. Self Assembly Customers agree and acknowledge that they are solely responsible for carrying out hydrostatic pressure testing of 100% of such assemblies to 1¹/₂ times the Maximum Working Pressure (MWP) of the hose assembly as specified in the relevant Full Product Brochure before supply for end use, to validate both the hose and the end fitting attachment.

(20) When pressure testing braided hoses with a plastic or rubber outer cover, the cover will mask any signs of leakage for a time. The Customer agrees and acknowledges that after the hydrostatic pressure test, it is required to test each covered hose assembly with an internal helium gas pressure of 30 Bar (450 psi) for hose sizes up to 1" and 15 Bar (225 psi) for hose sizes above 1", with the hose assembly immersed in water to enable leak detection by gas bubbles, for a minimum test period of 5 minutes.

(21) The "Self Assembly" Customer agrees and acknowledges that it shall determine and approve the Design Suitability of the hose assemblies for their intended use before supply and that, except as set forth in Section 22, it shall indemnify and hold Aflex Hose harmless from any Claims and Losses arising from Design Suitability for a Self Assembly Customer. This includes proceeding in accordance with Section (7) and Section (8) above.

(22) Aflex Hose's liability is limited to Aflex Hose Products which are assembled by approved Self Assembly Customers if all the hose and fitting components were supplied by Aflex Hose or approved for use by Aflex Hose in writing, and they were assembled and tested in accordance with Aflex Hose's current Manufacturing and Testing Instructions, available to approved Self Assemblers in an I-Bay on the Aflex Hose website.

Untested Hose Assemblies

(23) Aflex Hose is sometimes requested by Customers to attach non-standard end fittings to hose assemblies which they, supply, and in some cases it is not possible to connect these fittings to the Aflex Hose pressure test system. In such cases a "concession not to test" is obtained from the Customer, and a label is attached to the hose assembly, warning that it requires pressure testing before use. The Customer agrees and acknowledges that Aflex Hose shall have no liability whatsoever if the Customer does not comply with the warning that requires pressure testing before use.

Force Majeure

(24) Aflex Hose shall not be liable for any delay in delivery, failure to deliver or default in performing in accordance with any Customer's order if the delay or default is due to: (a) fires, floods, strikes, or other labor disputes, accidents to Aflex Hose's production facilities, acts of sabotage, riots, natural disasters, difficulties procuring materials, shortages of raw materials, interference by civil or military authorities, whether legal or de facto, governmental restrictions, including but not limited to failure to obtain export licenses, delays in transportation or lack of transportation facilities, restrictions imposed by federal, state or other governmental legislation or, rules or regulations thereof, including a force majeure event occurring in respect to one of Aflex Hose's suppliers; or (b) any other cause beyond Aflex Hose's control.

Governing Law; Jurisdiction

(25) These Conditions of Sale and all rights, duties and obligations hereunder, including any and all other Customer agreements and orders shall be governed by and subject to English Law.

(26) The Customer acknowledges and agrees that any disputes arising out of or related in any way to this Agreement, including a breach of this Agreement, shall be brought exclusively in the courts of England, United Kingdom. Furthermore, Customer knowingly, voluntarily and irrevocably (a) consents to the exclusive jurisdiction of these courts, (b) waives any immunity or objection, including any objection to personal jurisdiction or the laying of venue or based on the grounds of forum non conveniens, which it may have from or to the bringing of the dispute in such jurisdiction, (c) waives any personal service of any summons, complaint or other process that may be made by any other means permitted by England, United Kingdom, (d) waives any right to trial by jury, (e) agrees that any such dispute will be decided by court trial without a jury, (f) understands that it is giving up valuable legal rights under this Section 26, including the right to trial by jury, and that it voluntarily and knowingly waives those rights.

Limitations of Liability

(27) Aflex Hose Products have not been designed or tested for use in aerospace, medical implantation or radioactive applications, and such use is therefore strictly prohibited unless written approval from Aflex Hose has been given. Customer agrees and acknowledges that it is aware of the limitations set forth in this Section 26 and hereby agrees that Aflex Hose shall not have any liability whatsoever in the event Customer uses Aflex Hose Products for aerospace, medical implantation or radioactive applications. Customer agrees to indemnify Aflex Hose, its officers, directors, employees, affiliates and representatives for any and all Claims and Losses arising out of Customer's use of the Aflex Hose Products for aerospace, medical implantation or radioactive applications.

(28) Aflex Hose will not accept liability for any failures of the Aflex Hose Products which are caused by Customers failing to perform their Responsibilities as specified in these Conditions of Sale.

(29) NOTWITHSTANDING ANYTHING TO THE CONTRARY HEREIN, IN NO EVENT SHALL AFLEX HOSE BE LIABLE FOR ANY SPECIAL, INDIRECT, INCIDENTAL, CONSEQUENTIAL, EXEMPLARY, OR PUNITIVE DAMAGES, LOSS OF PROFITS OR REVENUE, LOSS OF PROCESS PRODUCTS, DAMAGE TO EQUIPMENT, DOWNTIME COSTS, OR LOSS OF USE EVEN IF INFORMED OF THE POSSIBILITY OF SUCH DAMAGES. TO THE EXTENT PERMITTED BY APPLICABLE LAW, THESE EXCLUSIONS AND LIMITATIONS WILL APPLY REGARDLESS OF WHETHER LIABILITY ARISES FROM FAILURE OF THE PRODUCT(S), BREACH OF CONTRACT, FAILURE TO DELIVER ON TIME, WARRANTY, TORT (INCLUDING, BUT NOT LIMITED TO, NEGLIGENCE), BY OPERATION OF LAW, OR OTHERWISE.

Notice Provisions

(30) Any written notice required to be provided to Aflex Hose shall be sent to the following address: Aflex Hose Limited, Spring Bank Industrial Estate, Watson Mill Lane, Sowerby Bridge, Halifax, West Yorkshire, HX6 3BW.

Exclusion of CISG

(31) The United Nations Convention on Contracts for the International Sale of Goods shall not apply to these Conditions of Sale and any and all other Customer documents.



Aflex Hose Ltd

World's Leading Manufacturer of PTFE Flexible Hose



The World's Leading Manufacturer of PTFE Flexible Hose.

Spring Bank Industrial Estate, Watson Mill Lane,
Sowerby Bridge, Halifax, West Yorkshire HX6 3BW
Te: +44 (0) 1422 317200 Fax: +44 (0) 1422 836000
Website: www.aflex-hose.com



Certificate No. 1977